

# **APPENDIX G – DESIGN CRITERIA FOR EROSION AND SEDIMENT CONTROL**

## **1.0 INTRODUCTION**

These guidelines are intended to provide the designer, contractor and builder with design criteria and minimum standards for the installation of erosion and sediment controls to comply with the Erosion and Sediment Control Regulations. The regulations were enacted to protect the health, safety, and property of the citizens and to help protect area water resources from pollution due to erosion and transportation of sediment. The regulations are applicable to all land development and land disturbance activity within the regulated MS4 area where the area of disturbance is more than one acre. The regulations require that no person cause or allow sediment to be deposited in any public street, public land, or on any property not under their control as a result of land disturbance from construction activities.

You can comply with the regulations by meeting the following objectives:

- a. Minimize the area disturbed by construction and development;
- b. Provide for containment of sediment until areas are stabilized;
- c. Stabilize disturbed areas as soon as practical after project completion; and
- d. Provide permanent erosion, drainage, and detention controls.

## **2.0 GENERAL DESIGN GUIDELINES**

Erosion is a natural process where soil and rock are loosened and removed. Natural erosion normally occurs at a very slow pace, but when land is disturbed on a construction site, the erosion rate often increases dramatically. When erosion occurs on a construction site and runoff carries sediment off the site, there is often a negative impact on downstream drainage systems and water quality.

The purposes of erosion and sediment controls are to minimize the amount of erosion that occurs as a result of construction activity and to prevent the sediment that is produced from leaving the property. Effective erosion and sediment control requires that the soil surface be protected from the erosive forces of wind, rain, and runoff and that the eroded soil be captured and retained onsite. The following principles are effective when they are integrated into a system of control practices and management techniques to control erosion and prevent sedimentation offsite.

When designing sediment and erosion controls, it is necessary to determine whether there is sheet flow or concentrated flow of stormwater on the property. Sheet flow occurs on gently sloping land without defined drainage ways. The stormwater tends to disperse evenly across the property, although the drainage may be in one direction due to the overall slope of the property. Concentrated flow occurs on property where there are defined drainageways that may range from gentle swales to clearly defined waterways. It is possible to have a combination of sheet flow and concentrated flow on the same property.

### **2.01 Erosion Protection**

Proper planning will help identify potential erosion problems, particularly highly susceptible areas, such as areas of concentrated flow. Removing the vegetative cover and altering the soil structure by clearing, grading, and compacting the surface increases an area's susceptibility to erosion. Scheduling can be a very effective means of reducing erosion. Schedule construction activities to minimize the exposed area and the duration of exposure. Apply stabilizing measures as soon as possible after the land is disturbed. Plan and implement temporary or permanent vegetation, mulches, or other protective practices to correspond with construction activities. Protect channels from erosion forces by using protective linings and the appropriate channel design. Consider possible future repairs and maintenance of these practices in the design. In scheduling, take into account the season and the weather forecast.

Clearing existing vegetation reduces the surface roughness and infiltration rate and increases runoff velocities and volumes. This is particularly a concern in areas of concentrated flow. Use measures that break the slopes to reduce the problems associated with concentrated flow volumes and runoff velocities. Practical ways to reduce velocities include conveying stormwater runoff away from steep slopes to stabilized outlets, preserving natural vegetation where possible, and mulching and vegetating exposed areas immediately after construction.

## **2.02 Sediment Containment**

Even with careful planning some erosion is unavoidable, and the resulting sediment must be trapped on the site. In areas where runoff occurs primarily as sheet flow, containment of sediment is relatively simple. In these areas, temporary containment devices may be sufficient. Where concentrations of flow occur, containment of sediment becomes more difficult as the rate and volume of flow increase. In these areas, more extensive or permanent control devices need to be provided. Areas of steep topography and cut or fill slopes need to be given special consideration. Due to the environmental sensitivity of streams, rivers, losing streams, sinkholes, and other karst topographic features, special consideration also needs to be given to these areas. Plan the location where sediment deposition will occur and maintain access for periodic removal of accumulated sediment. Protect low points below disturbed areas by building barriers to reduce sediment loss. Sediment traps and basins should be constructed before other land-disturbing activities.

## **2.03 Temporary Versus Permanent Controls**

Temporary controls, such as straw bale dikes, silt fences, erosion control blankets, etc., are provided for the purpose of controlling erosion and containing sediment until construction is complete. Temporary controls are not needed after the area is stabilized.

Permanent controls consist of riprap, detention basins, etc., which will remain in place through the life of the development. It is possible for the same facility to serve both a temporary and permanent purpose.

## **2.04 Maintenance**

Inspection and maintenance are vital to the performance of erosion and sedimentation control measures. If not properly maintained, some practices may cause more damage than they prevent. Always evaluate the consequences of a measure failing when considering which control measure to use, since failure of a practice may be hazardous or damaging to both people and property. For example, a large sediment

basin failure can have disastrous results, and low points in dikes can cause major gullies to form on a fill slope. It is essential to inspect all practices to determine that they are working properly and to ensure that problems are corrected as soon as they develop.

### **3.0 BMP DESCRIPTIONS AND DESIGN GUIDANCE**

#### **3.01 SCHEDULING**

##### DEFINITION AND PURPOSE:

This BMP involves developing, for every project, a schedule that includes sequencing of construction activities with the implementation of construction site BMPs such as temporary soil stabilization (erosion control) and temporary sediment control measures. The purpose is to reduce the amount and duration of soil exposed to erosion by wind, rain, runoff and vehicle tracking, and to perform the construction activities and control practices in accordance with the planned schedule.

##### APPROPRIATE APPLICATIONS:

Construction sequencing shall be scheduled to minimize land disturbance for all projects at all times.

##### CONDITIONS FOR EFFECTIVE USE:

All land disturbing activities.

##### WHEN BMP IS TO BE INSTALLED:

Scheduling should take place during the planning stages of the project.

##### STANDARDS AND SPECIFICATIONS:

Developing a schedule and planning the project are the very first steps in an effective storm water program. The construction schedule shall be incorporated into the SWPPP. Develop the sequencing and timetable for the start and completion of each item such as site clearing and grubbing, grading, excavation, paving, pouring foundations, installing utilities, etc., to minimize the active construction area during the rainy season. Schedule major grading operations for the non-rainy season when practical. Incorporate staged seeding and re-vegetation of graded slopes as work progresses. Consider scheduling when establishing permanent vegetation (appropriate planting time for specified vegetation).

##### OPERATION AND MAINTENANCE PROCEDURES:

Verify that work is progressing in accordance with the schedule. If progress deviates, take corrective actions. Amend the schedule when changes are warranted.

#### **3.02 PRESERVATION OF EXISTING VEGETATION**

##### DEFINITION AND PURPOSE:

Preservation of existing vegetation is the identification and protection of desirable vegetation that provides erosion and sediment control benefits.

APPROPRIATE APPLICATIONS:

Preserve existing vegetation at areas on a site where no construction activity is planned or will occur at a later date.

CONDITIONS FOR EFFECTIVE USE:

Protection of existing vegetation requires planning, and may limit the area available for construction activities.

WHEN BMP IS TO BE INSTALLED:

Preservation of existing vegetation shall be provided prior to the commencement of clearing and grubbing operations or other soil-disturbing activities in areas identified on the plans to be preserved.

STANDARDS AND SPECIFICATIONS:

Minimize the disturbed areas by locating temporary roadways to avoid stands of trees and shrubs and to follow existing contours to reduce cutting and filling. Mark areas to be preserved with temporary fencing at least 3.2 ft. tall. The fence post spacing and depth shall be adequate to completely support the fence in an upright position. Construction materials, equipment storage, and parking areas shall be located where they will not cause root compaction. Keep equipment away from trees to prevent trunk and root damage. Employees and subcontractors shall be instructed to honor protective devices. No heavy equipment, vehicular traffic, or storage piles of any construction materials shall be permitted within the drip line of any tree to be retained. Trenching shall be as far away from tree trunks as possible, usually outside of the tree drip line or canopy. The ends of damaged or cut roots shall be cut off smoothly.

OPERATION AND MAINTENANCE PROCEDURES:

During construction, limits of disturbance shall remain clearly marked at all times. If damage to protected trees occurs, the injured tree shall be attended to by an arborist.

SITE CONDITIONS FOR REMOVAL:

Temporary fencing shall be removed after final stabilization of the site has occurred.

**3.03 DUST (WIND EROSION) CONTROL**

DEFINITION AND PURPOSE:

Wind erosion control consists of applying water and/or other dust palliatives as necessary to prevent or alleviate erosion by the forces of wind. Alternatives to applying water or other dust palliatives include vegetative cover, wind barriers, and minimization of soil disturbance.

APPROPRIATE APPLICATIONS:

This practice is implemented on all exposed soils subject to wind erosion.

CONDITIONS FOR EFFECTIVE USE:

Effectiveness depends on soil, temperature, humidity and wind velocity.

WHEN BMP IS TO BE INSTALLED:

Routinely, especially in advance of and during periods of dry weather.

STANDARDS AND SPECIFICATIONS:

Water shall be applied by means of pressure-type distributors or pipelines equipped with a spray system or hoses and nozzles that will ensure even distribution. Phase work to the extent practical to minimize concurrent areas of soil disturbance. For areas not subjected to traffic, vegetation provides the most practical method of dust control and should be established as early as possible. Wind barriers such as solid board fences, snow fences, burlap fences, crate walls, and similar materials can be used to control air currents and blowing soil. Barriers placed at right angles to prevailing wind currents at intervals of about 10 times their height are effective in controlling soil blowing. Paved areas that have soil on them from construction sites should be cleaned regularly. Mulching offers a fast and effective means of controlling dust when properly applied. Binders and tackifiers may need to be used on organic mulches. NOTE: If calcium chloride or spray-on adhesives are used for dust control, a permit may be required from MoDNR.

OPERATION AND MAINTENANCE PROCEDURES:

Check areas that have been protected to ensure coverage.

SITE CONDITIONS FOR REMOVAL:

Dust control should be implemented while soils are exposed at the project.

### **3.04 HYDRAULIC MULCH-BONDED FIBER MATRIX**

DEFINITION AND PURPOSE:

Hydraulic mulch consists of applying a mixture of shredded wood fiber or a hydraulic bonded fiber matrix (BFM) and a stabilizing emulsion or tackifier with hydroseeding equipment, which temporarily protects exposed soil from erosion by raindrop impact or wind. BFMs adhere directly to the soil, eliminating gaps between the product and the soil. A water-insensitive crust does not form, therefore plant growth is not inhibited. Mulch and BFMs biodegrade completely into material known to be beneficial to plant growth. Seed may be applied simultaneously with mulching.

APPROPRIATE APPLICATIONS:

Hydraulic mulch and BFMs are applied to disturbed areas requiring temporary protection until permanent vegetation is established or disturbed areas that must be re-disturbed following an extended period of inactivity.

#### CONDITIONS FOR EFFECTIVE USE:

Type of Flow: Sheet flow only.

Wood fiber hydraulic mulches and BFMs are generally short-lived (only last part of a growing season) and need 24 hours to dry before rainfall occurs to be effective.

#### WHEN BMP IS TO BE INSTALLED:

Immediately after completion of a phase of grading.

#### STANDARDS AND SPECIFICATIONS:

Follow manufacturer's recommendations to maximize usefulness. Avoid mulch over-spray onto the traveled way, sidewalks, and lined drainage channels. Materials for wood fiber-based hydraulic mulches and bonded fiber matrices shall meet environmental quality standards and not be a detriment to stormwater discharges from the site.

#### OPERATION AND MAINTENANCE PROCEDURES:

Inspect at least every week and after every storm until vegetation is fully established. Repair eroded areas and reapply product and vegetation.

#### SITE CONDITIONS FOR REMOVAL:

Typically left in place to degrade naturally.

### **3.05 MULCHING**

#### DEFINITION AND PURPOSE:

A layer of organic material designed to protect exposed soil or freshly seeded areas from erosion by eliminating direct impact of precipitation and slowing overland flows. Mulch materials may include, but are not limited to, such things as grass, hay, straw, wood chips, wood fibers, and shredded bark.

#### APPROPRIATE APPLICATIONS:

Typically used for soil stabilization as a temporary surface cover on disturbed areas until soils can be prepared for revegetation and permanent vegetation is established. Installed in landscape areas for permanent use.

#### CONDITIONS FOR EFFECTIVE USE:

Type of Flow: Sheet flow only

The use of appropriate mulch will help ensure the vegetation is established under normal conditions and is essential to seeding success under harsh site conditions. General mulch recommendations to protect from raindrop splash and sheet flow include: straw applied at 2-2.5 tons/acre, wood fiber or wood cellulose applied at 0.5-1 ton/acre, wood chips applied at 5-6 tons/acre, and bark applied at 35 yd<sup>3</sup>/acre.

Where slopes are 25 percent (4:1) or greater grade, hydromulch, bonded fiber matrix, or erosion control blankets are required.

WHEN BMP IS TO BE INSTALLED:

Immediately after grading landscaped areas or seeding other areas.

STANDARDS AND SPECIFICATIONS:

Install upstream BMPs to protect area to be mulched. Rough grade area and remove all debris larger than 1 inch if area is to be vegetated and mowed in the future, larger than 2 inches if area is to be permanently mulched. If area is to be seeded, follow requirements of Seeding BMP. Spread mulch evenly.

OPERATION AND MAINTENANCE PROCEDURES:

Inspect at least every week and after every storm until adequate vegetation is established; annually for permanent mulch. Protect from vehicular and foot traffic. Repair damaged, degraded or eroded areas- reseed as needed and replace mulch.

### **3.06 SEEDING/MULCHING**

DEFINITION AND PURPOSE:

Establishment of vegetation by spreading grass seed designed to protect exposed soil from erosion by eliminating direct impact of precipitation and slowing overland flow rates. Once established, the vegetative cover will also filter pollutants from the runoff.

APPROPRIATE APPLICATIONS:

Exposed soil after a phase of rough or finish grading has been completed, or areas where no activity will occur for 14 days.

CONDITIONS FOR EFFECTIVE USE:

Type of Flow: Sheet flow and concentrated flow (additional stabilization is necessary).

Minimum Rates: Permanent seeding shall consist of 90% tall fescue and 10% annual ryegrass. Seed mixture to be applied at 400 pounds/acre. Temporary seeding shall consist of any combination of tall fescue, annual ryegrass, millet, wheat or oats. Seed mixture to be applied at 200 pounds/acre. Dormant season seeding, see mix shall consist of 80% tall fescue, 10% annual ryegrass and 10% spring oats. Seed mixture to be applied at 600 pounds/acre.

Acceptable Dates: Permanent seeding may be done March 1 to June 1 and August 15 to November 1. Temporary seeding can occur during any season, however winter is the least tolerant. Dormant season seeding includes December 15 to February 29.

WHEN BMP IS TO BE INSTALLED:

Immediately after rough or finished grading is completed.

STANDARDS AND SPECIFICATIONS:

Install upstream BMPs to protect area to be seeded. Complete grading and remove all debris larger than 1 inch. Loosen compacted soils to a depth of 4 inches. Groove or furrow on the contour if necessary. Spread loose topsoil at a depth of 4 inches.

Soil amendments should be applied per soil tests. When these are not available, lime shall be applied at the rate of 1500 pounds effective neutralizing material per acre. Soils with a pH of six or higher need not be limed. When soil tests are not available, a 13-13-13 grade fertilizer shall be applied at a rate of 500 pounds/acre for permanent seeding and a 10-10-10 grade fertilizer shall be applied at the rate of 200 pounds/acre. Mix soil amendments (lime, fertilizer, etc.) into the top 4 inches of soil.

Plant seed ¼ to ½ inches deep using a cyclone seeder, drill, cultipacker seeder, or hydro-seeder. Roll lightly to firm surface. Cover seeded area with mulch. Install additional stabilization (erosion control blankets, netting, bonded fiber matrix, etc.) on slopes steeper than 3:1 and in areas of concentrated flow. Water immediately. Provide enough to soak 4 inches into the soil without causing runoff.

OPERATION AND MAINTENANCE PROCEDURES:

Inspect at least weekly and after every storm. Protect seeded areas from vehicular and foot traffic. Reseed and mulch areas that have not sprouted within 21 days of planting. Repair damaged or eroded areas and reseed/mulch and stabilize as needed. Do not mow until 4 inches of growth occurs. During the first 4 months, mow no more than 1/3 the grass height.

**3.07 SODDING**

DEFINITION AND PURPOSE:

A ¾ inch to 1 inch mat of vigorous turf, free from disease, insects and weeds. Sod prevents raindrops from disrupting the soil structure and causing erosion. Sod slows water runoff and acts as a filter when sediment laden runoff crosses over the sodded area.

APPROPRIATE APPLICATIONS:

Typically installed in areas requiring immediate erosion protection, such as swales or detention ponds and as filter strips, around inlets, and adjacent to curbs. Also installed in areas requiring immediate aesthetic appearance or function such as entrances to new subdivisions and off site construction areas.

CONDITIONS FOR EFFECTIVE USE:

Type of Flow: Sheet flow and low concentrated flows with velocities less than 5 fps.

WHEN BMP IS TO BE INSTALLED:

Immediately after finish grading, installation of area inlets, and installation of underground services and foundations of new homes.



### STANDARDS AND SPECIFICATIONS:

Rough grade area and remove all debris larger than ½ inch in diameter and concentrated areas of smaller debris. Soil preparation of area to be sodded shall be determined by tests to determine lime and fertilizer requirements. Scarify soil and level to provide an even grade. Soil should not be excessively wet or dry. Lay first row of sod perpendicular to the slope or direction of flow. Butt subsequent rows tight against previous rows with strips staggered in brick-like pattern. Fill minor gaps with good soil and roll entire surface to ensure contact. Stake, staple and/or net corners and centers of sod strips as required, especially areas of concentrated flow. Water immediately after installation. Provide enough to soak 4 inches into the soil without causing runoff.

### OPERATION AND MAINTENANCE PROCEDURES:

Water sod daily for 3 weeks, enough to soak 4 inches into the soil without causing runoff. Reposition areas of sod that have moved along the slope. Remove sediment accumulations, replace sod if necessary. Repair any eroded areas, replace sod, and stabilize as needed. Do not mow until 3 inches of new growth occurs. During the first 4 months, mow no more than 1/3 the grass height.

## **3.08 ROLLED EROSION CONTROL PRODUCTS**

### DEFINITION AND PURPOSE:

Rolled erosion control products include erosion control blankets and turf reinforcement mats. Erosion control blankets are preformed protective blanket of plastic fibers, wood fibers, straw or other plant residue designed to protect soil from the impact of precipitation and overland flow, and retain moisture to facilitate establishment of vegetation. Turf reinforcement mats include netting designed to anchor the root system of the vegetation growing through it.

### APPROPRIATE APPLICATIONS:

Typically installed on seeded areas for temporary use, and in landscaped areas for permanent use.

### CONDITIONS FOR EFFECTIVE USE:

Several factors, such as soil conditions, steepness and length of slope, depth of flow, runoff velocities, and time required to establish desired vegetation, influence the choice of product. Manufacturer's recommendations should be followed. Products are available for a variety of uses: Netting-synthetic or natural fiber mesh installed over disturbed areas to hold organic mulch and/or seed in place, Biodegradable Erosion Control Blanket-natural fiber blanket held together by netting to provide temporary erosion protection on slopes and channels, and Permanent Erosion Control Blanket-synthetic blanket material which provides permanent erosion control on slopes and channels with increased water flow velocities.

### WHEN BMP IS TO BE INSTALLED:

Dependent upon intended use-immediately after completion of a phase of grading, or installation of vegetation.

### STANDARDS AND SPECIFICATIONS:

Follow manufacturer's recommendations and specifications, particularly noting requirements for check slots, fastening devices and need for firm contact with soil.

### OPERATION AND MAINTENANCE PROCEDURES:

Inspect at least every week and after every storm until adequate vegetation is established. Repair erosion and/or undermining at top of slope. Repair undermining beneath blankets-pull back the blanket(s), fill compact eroded area, revegetate and then firmly secure the blanket(s). Reposition or replace blanket(s) that have moved along the slope or have been damaged.

### SITE CONDITIONS FOR REMOVAL:

Temporary blankets will generally degrade naturally; permanent blankets remain in place.

### STANDARD DRAWING: ESC-1

## **3.09 GEOTEXTILES AND PLASTIC COVERS**

### DEFINITION AND PURPOSE:

This Best Management Practice (BMP) involves the placement of geotextiles or plastic covers to stabilize disturbed soil areas and protect soils from erosion by wind or water.

### APPROPRIATE APPLICATIONS:

Limited applications include very small graded areas and stockpiles.

### CONDITIONS FOR EFFECTIVE USE:

Type of Flow: Sheet and concentrated flows.

Geotextiles and plastic covers have maximum flow rate limitations; consult the manufacturer for proper selection. The use of plastic shall be limited to very short periods of time. The use of plastics and impermeable geotextiles may result in 100% runoff, which may cause serious erosion problems in the areas receiving the increased velocities and flow-Use with caution. Plastic sheeting is easily vandalized, easily torn, and photodegradable.

### WHEN BMP IS TO BE INSTALLED:

Immediately after completion of a phase of grading.

### STANDARDS AND SPECIFICATIONS:

Geotextile blankets shall be secured in place with wire staples or sandbags and by keying into tops of slopes and edges to prevent infiltration of surface water under the geotextile. Plastic sheeting shall be keyed in at the top of the slope and firmly held in place with sandbags or other weights placed no more than 10 feet apart. Seams are typically taped or weighted down their entire length. Anchoring the sheeting is crucial in protecting the sheeting in windy weather.

### OPERATION AND MAINTENANCE PROCEDURES:

All geotextile and plastic sheeting shall be inspected on a weekly basis and after storms to check for erosion, undermining, and anchorage failure. Any failures shall be repaired immediately. If washout or breakages occur, the material shall be re-installed after repairing the damage to the slope.

### SITE CONDITIONS FOR REMOVAL:

Upon establishment other temporary stabilizations or after permanent stabilization has occurred.

## **3.10 OUTLETS/VELOCITY DISSIPATION DEVICES**

### DEFINITION AND PURPOSE:

These devices are placed at pipe outlets to prevent scour and reduce the velocity and/or energy of storm water flows. These devices protect the receiving area from erosion.

### APPROPRIATE APPLICATIONS:

These devices may be used at the following locations: outlets of pipes, drains, culverts, slope drains, diversion ditches, swales, conduits or channels, outlets located at the bottom of mild to steep slopes, discharge outlets that carry continuous flows of water, outlets subject to short, intense flows of water, such as flash floods, points where lined conveyances to unlined conveyances, and at emergency overflows or outlet pipes of a sediment basin.

### CONDITIONS FOR EFFECTIVE USE:

Type of Flow: Concentrated flow

### WHEN BMP IS TO BE INSTALLED:

With the construction of the upstream BMP that creates the concentrated discharge.

### STANDARDS AND SPECIFICATIONS:

Install riprap, concrete apron, etc. at selected outlet. Riprap aprons are best suited for temporary use during construction. Carefully place riprap to avoid damaging the filter fabric. Align the apron with the receiving stream and keep straight throughout its length. If a curve is needed to fit site conditions, place it in the upper section of the apron. If the size of the apron riprap is comprised of large rocks, protect the underlying filter fabric with a gravel blanket. Outlets on slopes steeper than 10% need additional protection.

### OPERATION AND MAINTENANCE PROCEDURES:

Inspect at least every week and after every storm during construction. Remove sediment and trash accumulation. Inspect apron for displacement of the riprap and/or damage to the underlying fabric. Repair fabric and replace riprap that has washed away-larger rock may be required. Inspect for scour beneath the riprap and around the outlet. Repair damage to slopes immediately-extend pad if necessary.

### SITE CONDITIONS FOR REMOVAL:

Temporary devices need to be completely removed as soon as the surrounding drainage area has been stabilized, or at the completion of construction.

STANDARD DRAWING: ESC-2

### **3.11 TEMPORARY STREAM CROSSING**

#### DEFINITION AND PURPOSE:

A temporary stream crossing is a structure placed across a waterway that allows vehicles to cross the waterway during construction, minimizing, reducing, or managing erosion and downstream sedimentation caused by the vehicles. Use of temporary stream crossings is discouraged. Crossings are a direct source of pollution and should be avoided if alternatives are feasible.

#### APPROPRIATE APPLICATIONS:

Temporary stream crossings are installed at sites: where appropriate permits have been secured (404, 401, etc.), where construction equipment or vehicles need to frequently cross a waterway, when alternate access routes impose significant constraints, and where construction activities will be less than 1 year.

#### CONDITIONS FOR EFFECTIVE USE:

Design considerations include: current and proposed watershed conditions, average and peak discharge (2 year, 24 hour storm), effect on water surface elevation off-site, velocity, sediment removal, and protection of fish and trees. Criteria for a Low Water Crossing includes: any constant flow less than 3” deep, light traffic, bank height less than 5 feet, and perpendicular to flow or with a slight upstream arc. Criteria for a culvert crossing includes: sized for 2 year, 24 hour storm with 1 foot freeboard and no flooding of offsite areas, pipe parallel to flow, embankment perpendicular to channel or with a slight upstream arc, riprap on exposed faces sized for overtopping during a peak storm period.

#### WHEN BMP IS TO BE INSTALLED:

During dry periods-installation may require dewatering or temporary diversion of the stream.

#### STANDARDS AND SPECIFICATIONS:

Procedures are specific to the type of crossing used. Generally, provide a stable means to bypass normal channel flow prior to disturbing channel, stabilize channel bottom, install culvert (if used), grade and compact access ramps and soil embankment, install fabric, stone, and riprap according to design.

#### OPERATION AND MAINTENANCE PROCEDURES:

Inspect every week and after every storm-checking for: blockage in the channel, debris buildup, erosion of abutments, channel scour, riprap displacement, piping of soil, and structural weakening. Remove sediment and trash accumulation. Repair and stabilize eroded areas-extend riprap if necessary.

### SITE CONDITIONS FOR REMOVAL:

Remove as soon as alternative access is available. All foreign materials should be removed from creek. The streambed/banks should be returned to the original contour and stabilized if necessary.

STANDARD DRAWING: ESC-3

### **3.12 CHECK DAMS**

#### DEFINITION AND PURPOSE:

Check dams reduce scour and channel erosion by reducing flow velocity and encouraging sediment settlement. A check dam is a small device constructed of rock, gravel bags, sandbags, fiber rolls, or other proprietary product placed across a natural or man-made channel or drainage ditch.

#### APPROPRIATE APPLICATIONS:

Check dams can be placed at intervals along drainage swales or channels. The top of the downstream check dam should be level with the base of the upstream check dam. Check dams can also be used during the establishment of grass linings in drainage ditches or channels or in temporary ditches where the short length of service does not warrant establishment of erosion-resistant linings.

#### CONDITIONS FOR EFFECTIVE USE:

Type of Flow: Moderate concentrated flow.

Not to be used in live streams.

#### WHEN BMP IS TO BE INSTALLED:

Prior to disturbance of natural vegetation in contributing drainage area; immediately after construction of drainageway.

#### STANDARDS AND SPECIFICATIONS:

Check dams should be placed at a distance and height to allow small pools to form behind them. Install the first check dam approximately 16 feet from the outfall device and at regular intervals based on slope gradient and soil type. For multiple check dam installation, backwater from the downstream check dam should reach the toe of the upstream dam. High flows (typically a 2-year storm or larger) should safely flow over the check dam without an increase in upstream flooding.

#### OPERATION AND MAINTENANCE PROCEDURES:

Inspect at least every week and after every storm. Remove trash and leaf accumulation. Remove sediment when depth reaches one-half of the check dam height. Repair/restore dam structure, if necessary, to original configuration to protect the banks.

#### SITE CONDITIONS FOR REMOVAL:

Remove after contributing areas have been adequately stabilized and vegetation is adequately established in drainageway. Regrade and vegetate area of check dam.

STANDARD DRAWING: ESC-4

### **3.13 EARTH BERMS AND DRAINAGE SWALES**

#### DEFINITION AND PURPOSE:

A compacted earth, compost or gravel ridge, excavated channel or a combination of ridge and channel designed to direct runoff away from or around disturbed areas. Diversions built on a level contour are used in combination with temporary slope drains to provide adequate conveyance. Diversions built with positive drainage slopes release runoff into additional BMPs, such as sediment traps or level spreaders.

#### APPROPRIATE APPLICATIONS:

These features may be used to: convey surface runoff down sloping land, intercept and divert runoff to avoid sheet flow over sloped surfaces, divert and direct runoff towards a stabilized watercourse, drainage pipe or channel, intercept runoff from paved surfaces. Berms, swales, and lined ditches also may be used: below steep grades where runoff begins to concentrate, along roadways and facility improvements subject to flood drainage, at the top of slopes to divert run-on from adjacent or undisturbed slopes. And at bottom and mid-slope locations to intercept sheet flow and convey concentrated flows.

#### CONDITIONS FOR EFFECTIVE USE:

Type of Flow: Sheet flow and low-volume concentrated flows.

Contributing Area: Contributing slope length-300 feet maximum; 100 feet for slopes greater than 5%.

#### WHEN BMP IS TO BE INSTALLED:

Prior to disturbance of natural vegetation on slopes and at intervals during construction of fill slopes.

#### STANDARDS AND SPECIFICATIONS:

Care must be applied to correctly size and locate berms, swales, and ditches. Excessively steep, unlined berms and swales are subject to gully erosion. Grade and compact channel and/or ridge. Conveyances should be stabilized with vegetation or a protective lining. Provide stabilized outfall areas. Other BMPs, such as check dams and erosion control blankets, may be necessary to prevent scour and erosion.

#### OPERATION AND MAINTENANCE PROCEDURES:

Inspect at least every week and after every storm. Inspect channel linings, embankments, and beds of ditches and berms for erosion and accumulation of debris and sediment. Remove debris and sediment, repair linings and embankments as needed-replace riprap, linings or soil stabilizers as needed.

#### SITE CONDITIONS FOR REMOVAL:

Temporary diversions should be removed as soon as the surrounding drainage area has been stabilized.

STANDARD DRAWING: ESC-5

### **3.14 TERRACING**

#### **DEFINITION AND PURPOSE:**

Terracing involves defined swales constructed at regular intervals along the face of a slope designed to reduce erosion by capturing surface runoff and directing it to an adequate, stable outlet.

#### **APPROPRIATE APPLICATIONS:**

Typically installed on long steep slopes on which erosion is a concern. Terraces should not be constructed in sandy or rocky soil.

#### **CONDITIONS FOR EFFECTIVE USE:**

Type of Flow: Sheet flow.

Slope Characteristics: Maximum of 3:1 slope.

Contributing Slope Length: Maximum of 30 feet for slopes steeper than 4:1; maximum for 50 feet for 4:1 and flatter.

#### **WHEN BMP IS TO BE INSTALLED:**

Installed as fill is constructed. On existing slopes, terraces should be graded prior to removal of vegetation.

#### **STANDARDS AND SPECIFICATIONS:**

Grade terraces as required by the design. Construct the stable outfall as designed. Vegetate the slope and terraces.

#### **OPERATION AND MAINTENANCE PROCEDURES:**

Inspect at least every week and after every storm during construction. Remove sediment accumulations along terraces. Repair settled and eroded areas. Remove sediment and stabilize eroded areas at outlet. Revegetate as needed

**STANDARD DRAWING:** ESC-6

### **3.15 SLOPE DRAINS**

#### **DEFINITION AND PURPOSE:**

A slope drain is a flexible or rigid pipe which extends from the top to the bottom of a cut or fill slope. These structures are designed to protect exposed slopes from upstream runoff and can be used with other BMPs to intercept and direct surface flow away from disturbed slope areas. Slope drains typically extend beyond the toe of the slope to a stable area or outlet.

APPROPRIATE APPLICATIONS:

Slope drains may be used on construction sites where slopes may be eroded by surface runoff.

CONDITIONS FOR EFFECTIVE USE:

Type of Flow: Sheet flow and concentrated flow.

Contributing Area: Maximum of 5 acres per slope drain; pipe sized for 15 year, 20 minute storm.

WHEN BMP IS TO BE INSTALLED:

Concurrently with diversion devices as soon as cut and fill operations have occurred.

STANDARDS AND SPECIFICATIONS:

Slope drains must be installed and maintained properly because failure will usually result in severe erosion of the slope. Other points of concern are failure from overtopping due to inadequate pipe inlet capacity or blockage, and lack of maintenance of the upstream diversion device capacity. Generally install slope drain down the slope-perpendicular to slope contours, extending beyond toe of slope. Install flared end or t-section at pipe inlet. Section should be well entrenched and stable so water can enter freely. Compact fill over and around pipe in area of diversion device. Ensure that all pipe connections are secure. Securely anchor the exposed section of the drain with stakes. Install flared end section at pipe outlet-discharge into a sediment trap or other stabilized outlet. Protect area around inlet with filter fabric. Protect outlet with riprap or other energy dissipation device.

OPERATION AND MAINTENANCE PROCEDURES:

Inspect at least every week and after every storm during construction. Remove sediment and trash accumulation at inlet. Repair settlement, cracking, or piping holes. Repair leaks or inadequate anchoring along pipe. Remove sediment and stabilize eroded areas at outlet-extend if necessary.

SITE CONDITIONS FOR REMOVAL:

Remove concurrently with upstream diversion device after slope has been stabilized. Stabilize the exposed areas where the slope drain and diversion device were removed.

STANDARD DRAWING: ESC-7

**3.16 SOIL ROUGHENING**

DEFINITION AND PURPOSE:

Soil roughening is a temporary erosion control practice often used in conjunction with grading. Soil roughening involves increasing the relief of a bare soil surface with horizontal grooves by either stair-stepping (running parallel to the contour of the land) or using construction equipment to track the surface. Slopes that are not fine graded and left in a roughened condition can also reduce erosion. Soil roughening reduces runoff velocity, increases infiltration, reduces erosion, traps sediment, and prepares the soil for seeding and planting by giving seed an opportunity to take hold and grow.



### APPROPRIATE APPLICATIONS:

Soil roughening is appropriate for all slopes, but works especially well on slopes greater than 3:1, on piles of excavated soil, and in areas with highly erodible soils. This technique is especially appropriate for soils that are frequently disturbed, because roughening is relatively easy.

### CONDITIONS FOR EFFECTIVE USE:

Type of Flow: Sheet flow.

Contributing Area: Unlimited on slopes <10%, slopes >10% require additional BMPs

### WHEN BMP IS TO BE INSTALLED:

Immediately after rough grading; prior to seeding or mulching.

### STANDARDS AND SPECIFICATIONS:

Depending on the type of slope and the available equipment, use different methods for roughening soil on a slope. These include stair-step grading, grooving, and tracking. When choosing a method, consider factors such as slope steepness, mowing requirements, whether the slope is formed by cutting or filling, and available equipment. Soil roughening is not appropriate for rocky slopes. Tracked machinery can excessively compact the soil, therefore light weight machinery should be considered.

### OPERATION AND MAINTENANCE PROCEDURES:

Inspect at least every week and immediately after every storm. Rework the slope and regroove after sediment buildup is deeper than ½ the groove depth. Rework the slope and regroove if rills have cut across the roughened surface.

### SITE CONDITIONS FOR REMOVAL:

The slope should be reworked to the design grades immediately prior to final stabilization.

## **3.17 FIBER ROLLS/WATTLES**

### DEFINITION AND PURPOSE:

Fiber rolls (also called fiber logs or straw wattles) are tube-shaped erosion-control devices filled with straw, flax, rice, coconut fiber material, or composted material. Each roll is wrapped with UV-degradable polypropylene netting for longevity or with 100 percent biodegradable materials like burlap, jute, or coir. These devices reduce the effects of long or steep slopes by breaking up the slope length.

### APPROPRIATE APPLICATIONS:

Fiber rolls can be used in areas of low shear stress such as; along the toe, top, face, and at-grade breaks of exposed and erodible slopes to shorten slope length and spread runoff as sheet flow, at the end of a downward slope where it transitions to a steeper slope, along the perimeter of a project or stockpile, as check dams in unlined ditches, and downslope of exposed soil areas.

CONDITIONS FOR EFFECTIVE USE:

Type of Flow: Sheet flow and concentrated flow.

WHEN BMP IS TO BE INSTALLED:

Immediately after rough grading; prior to seeding or mulching.

STANDARDS AND SPECIFICATIONS:

On slopes, install fiber rolls along the contour with a slight downward angle at the end of each row to prevent ponding at the midsection. Turn the ends of each fiber roll upslope to prevent runoff from flowing around the roll. Determine the vertical spacing for slope installations on the basis of the slope gradient and soil type. A good rule of thumb is: 1:1 slopes=10 feet apart, 2:1 slopes=20 feet apart, 3:1 slopes=30 feet apart, and 4:1 slopes=40 feet apart. Stake fiber rolls securely into the ground and orient them perpendicular to the slope. Fiber rolls can also be used at projects with minimal slopes. Typically, the rolls are installed along sidewalks, on the bare lot side, to keep sediment from washing onto sidewalks and streets and into gutters and storm drains.

OPERATION AND MAINTENANCE PROCEDURES:

Inspect at least every week and after every storm. Remove sediment accumulation when it reaches ½ the height of the roll/wattle. Repair or replace split, torn, unraveled, or slumping fiber rolls.

SITE CONDITIONS FOR REMOVAL:

Fiber rolls are typically left in place on slopes. If they are removed after stabilization has been achieved, collect and dispose of the accumulated sediment.

STANDARD DRAWING: ESC-8

**3.18 VEGETATED FILTER STRIP**

DEFINITION AND PURPOSE:

Vegetated buffers are areas of natural or established vegetation maintained to protect the water quality of neighboring areas. Buffer zones slow stormwater runoff, provide an area where runoff can permeate the soil, contribute to ground water recharge, and filter sediment. Slowing runoff also helps to prevent soil erosion and streambank collapse.

APPROPRIATE APPLICATIONS:

Vegetated buffers can be used in any area able to support vegetation. They are most effective and beneficial on floodplains, near wetlands, along streambanks, and on unstable slopes. Filter strips can be used adjacent to low or medium density residential areas on gently sloping ground.

CONDITIONS FOR EFFECTIVE USE:

Type of Flow: Overland sheet flow only-cannot treat high velocity flows.

### WHEN BMP IS TO BE INSTALLED:

Immediately after rough grading to trap sediment during construction and/or immediately after final grading as a permanent measure to control surface runoff.

### STANDARDS AND SPECIFICATIONS:

Determine buffer widths after carefully considering slope, vegetation, soils, depth to impermeable layers, runoff sediment characteristics, type and amount of pollutants, and annual rainfall. Make sure buffer widths increase as slope increases. In areas where flows are more concentrated and fast, combine buffer zones with other practices such as level spreaders, infiltration areas, or diversions to prevent erosion and rilling. Fence off any undisturbed vegetated strips to be preserved. No activity, including parking/storing vehicles or equipment, shall be permitted in the vegetated/woody strip. If a grass filter strip is constructed, it must be completed and vegetated before construction in a contributing area is started.

### OPERATION AND MAINTENANCE PROCEDURES:

Inspect at least every week and after every storm. Remove sediment accumulation once it reaches 6" in depth. Fill and compact eroded areas and reseed, mulch and fertilize or establish other vegetation in the affected areas. After improvements are complete, regrade and reseed the top edge of the filter strip to remove sediment trapped during construction and prolong the effective use of the filter strip.

## **3.19 SILT FENCE**

### DEFINITION AND PURPOSE:

A silt fence consists of a length of filter fabric stretched between anchoring posts spaced at regular intervals along the site at low/downslope areas. The filter fabric should be entrenched in the ground at least 6". When installed correctly and inspected frequently, silt fences encourage the ponding of runoff and can be an effective barrier to sediment leaving the site in stormwater runoff.

### APPROPRIATE APPLICATIONS:

Installed along slopes, at base of slopes, and around the perimeter of a site as a final barrier to sediment being carried off site. Silt fence should not be used in areas of concentrated flow or as check dams.

### CONDITIONS FOR EFFECTIVE USE:

Type of Flow: Sheet flow only

Contributing Area: Drainage area should not exceed 0.25 acres per 100-foot fence length.

Slope Length: The slope length above the fence should not exceed 100 feet.

### WHEN BMP IS TO BE INSTALLED:

Prior to disturbance of natural vegetation and at intervals during construction of fill slopes.

### STANDARDS AND SPECIFICATIONS:

If a standard-strength fabric is used, it can be reinforced with wire mesh behind the filter fabric. This increases the effective life of the fence. The maximum life expectancy for synthetic fabric silt fences is about 6 months, depending on the amount of rainfall and runoff. The fence should be designed to withstand the runoff from a 10-year peak storm event. Generally, drive posts for fence line, dig trench to required dimensions in front of posts for fabric burial, attach wire mesh to posts (if necessary), attach fabric to posts-allowing required length below ground level to run fabric along bottom of trench, and backfill and compact soil in trench to protect and anchor fabric. Alternate (and actually preferred) construction procedures include installing the fence by slicing it into the ground with specialized equipment.

### OPERATION AND MAINTENANCE PROCEDURES:

Inspect at least every week and after every storm. Remove sediment buildup deeper than ½ the fence height. Replace torn/clogged fabric; repair loose fabric. Repair unstable or broken posts. Stabilize any areas susceptible to undermining. Add additional fencing if necessary to provide adequate protection.

### SITE CONDITIONS FOR REMOVAL:

After permanent vegetation of slope is established. Remove fence, regrade trench area and vegetate.

### STANDARD DRAWING: ESC-9

## **3.20 STRAW BALE DIKE**

### DEFINITION AND PURPOSE:

A straw bale dike consists of a series of straw (or hay) bales butted firmly end to end and anchored in place with stakes placed along the low/downslope areas of a site. The straw bales should be entrenched in the ground. When installed correctly and inspected frequently, straw bale dikes encourage the ponding of runoff and can be an effective barrier to sediment leaving the site in stormwater runoff.

### APPROPRIATE APPLICATIONS:

Installed along slopes, at base of slopes, and around the perimeter of a site as a final barrier to sediment being carried off site. Straw bale dikes should not be used in areas of significant concentrated flow as check dams.

### CONDITIONS FOR EFFECTIVE USE:

Type of Flow: Sheet flow and minimal concentrated flow.

Contributing Area: Drainage area should not exceed 0.25 acres per 100-foot fence length. For minor swales where the dike will serve as a ditch check, the drainage area shall not exceed 2 acres.

Slope Length: The slope length above the fence should not exceed 100 feet. Reduce this as the area above the dike steepens.

WHEN BMP IS TO BE INSTALLED:

Prior to disturbance of natural vegetation and at intervals during construction of fill slopes.

STANDARDS AND SPECIFICATIONS:

The maximum life expectancy for straw bale dikes is about 3 months, depending on the amount of rainfall and runoff. The dike should be designed to withstand the runoff from a 10-year peak storm event. The dike should be installed on level ground at least 10 feet from the toe of the slope. Excavate a trench at least 4" deep and a bale width wide and long enough that the end bales are upslope of the sediment pool. Anchor bales by driving two 36" long 2"x2" hardwood stakes through each bale until nearly flush with the top. Drive the first stake toward the previously laid bale to force the bales together. Wedge loose straw into any gaps between the bales. Backfill and compact the excavated soil against the bales to ground level on the downslope side and to 4" above ground level on the upslope side.

OPERATION AND MAINTENANCE PROCEDURES:

Inspect at least every week and after every storm. Remove sediment buildup deeper than 1/2 the dike height. Replace deteriorated or damaged bales. Repair unstable or broken stakes. Stabilize any areas susceptible to undermining. Add additional bales if necessary to provide adequate protection.

SITE CONDITIONS FOR REMOVAL:

After permanent vegetation of slope is established. Remove dike, regrade trench area and vegetate.

STANDARD DRAWING: ESC-10

### **3.21 SEDIMENT BASIN**

DEFINITION AND PURPOSE:

A temporary settling pond designed to slowly release runoff, detaining it long enough to allow most of the sediment to settle out. Basins should be used in conjunction with additional BMPs, such as temporary seeding, to reduce the total amount of sediment washing into them. Sediment basins may also be designed to be converted to permanent storm water detention basins after construction has ended.

APPROPRIATE APPLICATIONS:

Should be located as close to the sediment source as possible. A sediment basin should not be used in areas of continuously running water (live streams) nor areas where failure of the embankment will result in loss of life, damage to homes or structures, or prevent the use of roadways or utilities.

CONDITIONS FOR EFFECTIVE USE:

Type of Flow: Sheet flow and concentrated flow.

Basin Volume: Volume of 10 year, 20 minute storm plus silt load of 1800 cf/acre below riser top.

WHEN BMP IS TO BE INSTALLED:

Prior to disturbance of natural vegetation.

STANDARDS AND SPECIFICATIONS:

For permanent structures, a qualified professional engineer experienced in designing dams should complete the basin design. Excavate basin to length, width, depth and slopes specified on plans. Place and compact fill to construct dam to elevation at least 1 foot above crown of outlet pipe. Install outlet pipe and compact clay soil around pipe. Install the perforated riser pipe, wrap with fabric, and surround with uniformly graded gravel. Install energy dissipation at downstream end of outlet pipe. Complete installation of dam to an elevation 10% above design height to allow for settling. Grade and stabilize spillway. Install monitoring post near outlet of basin. Mark maximum allowable sediment depth.

OPERATION AND MAINTENANCE PROCEDURES:

Inspect at least every week and after every ½” storm. Remove trash accumulation at outlet. Remove sediment accumulations once sediment reaches design depth, as indicated on monitoring posts. Repair and revegetate any erosion damage on spillway. Repair settlement, cracking, piping holes, or seepage at embankment. Replace gravel around riser if basin does not drain properly.

SITE CONDITIONS FOR REMOVAL:

Remove after upstream areas are stabilized. Regrade as appropriate and vegetate immediately.

STANDARD DRAWING: ESC-11

**3.22 SEDIMENT TRAP**

DEFINITION AND PURPOSE:

A sediment trap is a temporary containment area that allows sediment in collected storm water to settle out during infiltration or before the runoff is discharged.

APPROPRIATE APPLICATIONS:

Sediment traps are commonly used at the outlets of stormwater diversion structures, channels, slope drains, construction site entrances, vehicle wash areas, or other runoff conveyances.

CONDITIONS FOR EFFECTIVE USE:

Type of Flow: Sheet flow and concentrated flow.

Contributing Area: Maximum of 5 acres.

Trap Volume: Silt load of 1800 cf/acre.

WHEN BMP IS TO BE INSTALLED:

Prior to disturbance of natural vegetation.

STANDARDS AND SPECIFICATIONS:

Take care to situate sediment traps for easy access by maintenance crews. Excavate an area for a sediment trap-make sure the side slopes are no steeper than 2:1 and the embankment height no more than 5 feet from the original ground surface. Install dewatering pipe, if necessary. Place and compact fill to construct embankments and the spillway. To reduce flow rate from the trap, line the outlet with rip rap and gravel over the dewatering pipe, if necessary. The spillway weir for each temporary sediment trap should be at least 4 feet long for a 1-acre drainage area and increase by 2 feet for each additional drainage acre added, up to a maximum drainage area of 5 acres. Install monitoring posts in the trap which mark ½ the design depth for sediment accumulation.

#### OPERATION AND MAINTENANCE PROCEDURES:

Inspect at least every week and after every ½” storm. Remove trash accumulation. Remove sediment accumulations once sediment reaches design depth, as indicated on monitoring posts. Repair and revegetate any erosion damage. Repair settlement, cracking, piping holes, or seepage at embankment.

#### SITE CONDITIONS FOR REMOVAL:

Remove after upstream areas are stabilized. Regrade as appropriate and vegetate immediately.

#### STANDARD DRAWING: ESC-12

### **3.23 CURB AND GUTTER INLET PROTECTION**

#### DEFINITION AND PURPOSE:

A temporary sediment control barrier consisting of a filter media, such as compost filter socks, gravel and mesh, sandbags, gravel bags, etc., around a curb and gutter inlet designed to prevent sediment from entering the storm sewer. Shallow temporary ponding during and after rainfall should be expected.

#### APPROPRIATE APPLICATIONS:

At inlets where runoff may contain sediment-laden water.

#### CONDITIONS FOR EFFECTIVE USE:

Type of Flow: Sheet flow and concentrated flow.

Contributing Area: Maximum of 1 acre.

#### WHEN BMP IS TO BE INSTALLED:

Immediately after installation of the inlet, or prior to land disturbing activities beginning on the contributing upstream area to the inlet.

#### STANDARDS AND SPECIFICATIONS:

Typical types of curb and gutter inlet protection include: fabricated inlet filters (follow manufacturer's instructions), compost filter sock (make sure that both ends of the sock are anchored accordingly), gravel and wire mesh (construct and anchor wood frame, fasten wire mesh and fabric to frame and place

the gravel on top of the entire structure), sandbags and gravel bags (may be placed either as a j-hook on the upstream end of the inlet or as a full barrier, sometimes stacked 2 bags high, across the entire opening of the inlet). Incorporate an overflow bypass into the inlet protection structure in areas, such as heavy traffic streets, where excessive ponding of water around the inlet may become a safety issue. Sediment controls behind the curb will be necessary to prevent the discharge of sediment in these bypasses.

**OPERATION AND MAINTENANCE PROCEDURES:**

Inspect inlet protection of all media types weekly and after each ½” rainfall event to make sure they are functioning properly. Remove trash and debris. Remove sediment from the inlet protection when half of the protection structure height has been filled. Repair elements to original configuration as needed.

**SITE CONDITIONS FOR REMOVAL:**

Remove after contributing drainage areas have been adequately stabilized.

**STANDARD DRAWING:** ESC-13

**3.24 DROP INLET PROTECTION**

**DEFINITION AND PURPOSE:**

A temporary sediment control barrier consisting of a filter fabric around a recessed area inlet designed to prevent sediment from entering the storm sewer. Shallow temporary ponding during and after rainfall should be expected.

**APPROPRIATE APPLICATIONS:**

At recessed area or yard inlets where runoff may contain sediment-laden water.

**CONDITIONS FOR EFFECTIVE USE:**

Type of Flow: Sheet flow and concentrated flow.

Contributing Area: Maximum of 1 acre.

**WHEN BMP IS TO BE INSTALLED:**

Immediately after installation of the inlet, or prior to land disturbing activities beginning on the contributing upstream area to the inlet.

**STANDARDS AND SPECIFICATIONS:**

Typical types of drop inlet protection include: manufactured filter bags-follow manufacturer’s instructions, block and gravel-blocks which are stacked should be anchored against movement, place geotextile filter fabric or wire mesh over the outside vertical face of the concrete blocks, place clean stone against the geotextile filter fabric/mesh up to the top of the concrete blocks, fabric drop-install wood frame, dig a trench around the inlet for fabric to be buried, fasten fabric tightly to frame, backfill



and compact trench, sod filter-prepare and fertilize soil, install sod for a distance of at least 4 feet in each direction, stake, staple and/or net corners and center of sod strips as required, water immediately. For safety, inlet protection structures which pond water onto streets, parking lots or driveways should be designed to have some method for allowing excess water from large storms to bypass or overflow.

OPERATION AND MAINTENANCE PROCEDURES:

Inspect inlet protection of all media types weekly and after each significant rainfall event to make sure they are functioning properly. Remove trash and debris. Remove sediment from the inlet protection when half of the protection structure height has been filled. Repair elements to original configuration as needed.

SITE CONDITIONS FOR REMOVAL:

Remove after contributing drainage areas have been adequately stabilized.

STANDARD DRAWING: ESC-14

**3.25 CONSTRUCTION ENTRANCE/EXIT**

DEFINITION AND PURPOSE:

A stabilized entrance to a construction site is designed to minimize the amount of sediment tracked from the site on vehicles and equipment. Mud and sediment fall off of tires as they travel along the stabilized entrance.

APPROPRIATE APPLICATIONS:

At locations where it is safe for construction vehicles and equipment to access existing streets-preferably at location of future streets or drives.

CONDITIONS FOR EFFECTIVE USE:

Site conditions will dictate design and need. Ditches or pipes, if needed, sized for 15 year, 20 minute storm; HGL 6" below surface of entrance.

WHEN BMP IS TO BE INSTALLED:

One of the first things done, prior to vehicles or equipment accessing unpaved areas.

STANDARDS AND SPECIFICATIONS:

Limit the points of entrance/exit to the construction site. Properly grade and compact each construction entrance/exit to prevent runoff from leaving the site. Install culvert under entrance if needed to maintain positive drainage. Place fabric and cover with aggregate, forming a diversion across the entrance, if needed, to direct runoff away from the roadway. Require all employees, subcontractors, and suppliers to utilize the stabilized construction access.

OPERATION AND MAINTENANCE PROCEDURES:

Inspect routinely for damage and assess effectiveness of the BMP. Remove sediment and clods of dirt from construction entrance continuously. Replace rock, if necessary, to maintain a clean surface. Repair any areas that have settled. Keep all temporary roadway ditches clear. Immediately remove any mud or debris tracked onto paved surfaces.

SITE CONDITIONS FOR REMOVAL:

Remove when vehicles and equipment will no longer access unpaved areas.

STANDARD DRAWING: ESC-15

**3.26 NON-SEDIMENT POLLUTION CONTROL**

DEFINITION AND PURPOSE:

These control measures are designed to prohibit chemicals, hazardous materials, solid waste, human waste and construction debris from polluting stormwater. Pollutants carried in solution or as surface films on runoff will be carried through most erosion control and sediment capture BMPs. Keeping substances like fuel, oil, asphalt, paint, solvents, fertilizer, soil additives, concrete wash water, solid waste, human waste and construction debris from polluting runoff can be accomplished to a large extent through good housekeeping on the site and following the manufacturer's recommendations for disposal.

APPROPRIATE APPLICATIONS:

Temporary sanitary facilities, collection, storage and fueling areas should be located onsite in an area that does not receive a substantial amount of runoff from upland areas and does not drain directly to lakes, creeks, streams, rivers, sewers, groundwater, wetlands, or road ditches.

CONDITIONS FOR EFFECTIVE USE:

An effective management system requires training and signage to promote proper storage, handling and disposal of materials, and follow up observations of actions and inspection of storage areas by management. Plans should contain notes clearly stating requirements for addressing potential pollutants.

WHEN BMP IS TO BE INSTALLED:

Immediately following installation of construction entrance.

STANDARDS AND SPECIFICATIONS:

Place waste receptacles near area of work. All fueling facilities present on the site shall adhere to applicable federal and state regulations concerning underground storage, above ground storage, and dispensers. Hazardous wastes shall be managed according to Missouri Hazardous Waste Laws and Regulations. Install appropriate signage. Post guidelines for proper handling, storage and disposal of materials, and emergency spill cleanup on site. Provide sufficient temporary toilet facilities to serve the number of workers on the site.

OPERATION AND MAINTENANCE PROCEDURES:

Inspect activities on a regular basis. Inspect storage areas and control devices at least every week and after every storm. Maintenance of temporary toilet facilities should be frequent and thorough. Make necessary corrections and repairs.

SITE CONDITIONS FOR REMOVAL:

Remove after contributing drainage areas have been adequately stabilized.

STANDARD NOTES:

See general pollution notes:

1. Handling and disposal of hazardous materials:

DO: Prevent spills

Use products up

Follow label directions for disposal

Remove lids from empty bottles and cans when disposing in trash

Recycle wastes whenever possible

DON'T: Don't pour waste into sewers or waterways on the ground

Don't pour waste down the sink, floor drain or septic tanks

Don't bury chemicals or containers, or dispose of them with other waste

Don't burn chemicals or containers

Don't mix chemicals together

2. Containers shall be provided for collection of all waste material including construction debris, trash, petroleum products and any hazardous materials to be used onsite. All waste material shall be disposed of at facilities approved for that material.

3. No waste materials shall be buried on-site.

4. Mixing, pumping, transferring or otherwise handling construction chemicals such as fertilizer, lime, asphalt, concrete drying compounds, and all other potentially hazardous materials shall be performed in an area away from any watercourse, ditch or storm drain.

5. Equipment fueling and maintenance, oil changing, etc., shall be performed only in an area designated for that purpose. The designated area is equipped for recycling oil and catching spills.

6. Concrete wash water shall not be allowed to flow directly to storm sewers, streams, ditches, lakes, etc without being treated. A sump or pit shall be constructed to contain concrete wash water.

7. All paint, solvents, petroleum products and petroleum waste products, and storage containers (such as drums, cans, or cartons) shall be stored according to BMPs. The materials exposed to precipitation shall be stored in watertight, structurally sound, closed containers. All containers shall be inspected for leaks or spillage during the once per week inspection of BMPs. If substances such as oil, diesel fuel, hydraulic fluid,

antifreeze, etc. are spilled, leaked, or released onto soil, the soil shall be dug up and properly disposed of. Spills on pavement shall be absorbed with sawdust, kitty litter or product designed for that purpose and disposed of at a licensed sanitary landfill. Hazardous or industrial wastes such as most solvents, gasoline, oil-based paints, and cement curing compounds require special handling. These materials will be removed from the site and recycled or disposed of in accordance with MoDNR requirements.

8. State law requires the party responsible for a petroleum product spill in excess of 50 gallons to report the spill to MoDNR (537-634-2436) as soon as practical after discovery. Federal law requires the responsible party to report any release of oil if it reaches or threatens a sewer, lake, creek, stream, river, groundwater, wetland, or area, like a road ditch, that drains into one of the above.

9. Sufficient temporary toilet facilities to serve the number of workers on the site shall be provided. The facilities shall be serviced frequently to maintain a sanitary condition.

Upper Entrenchment  
(Key Trench at  
Top of Slope Shown)

Anchor (Typ)

Overlap Joint  
(Typ)

Lower Entrenchment  
(Key Trench at  
Toe of Slope Shown)

**NOTE:**

BRING MATERIAL DOWN TO A LEVEL AREA  
BEFORE TERMINATING THE INSTALLATION.

**NOTE:**

WHERE THERE IS A BERM AT  
THE TOP OF THE SLOPE,  
BRING THE MATERIAL OVER  
THE BERM AND ANCHOR  
IT BEHIND THE BERM.

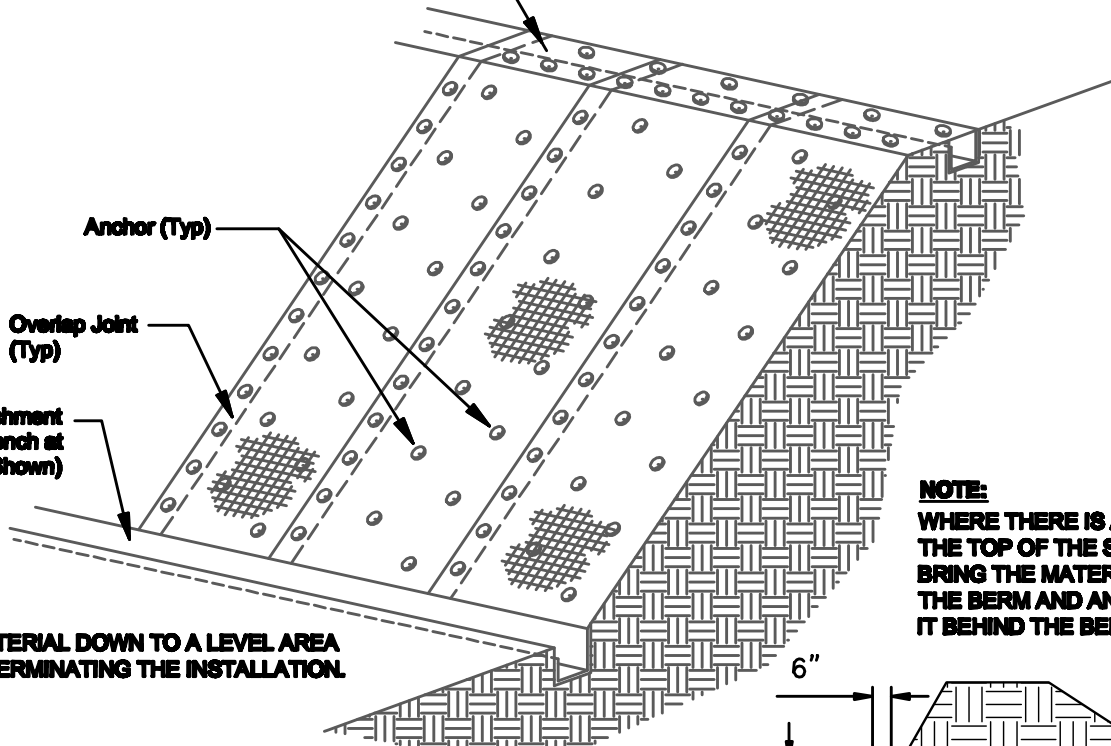

**ISOMETRIC**

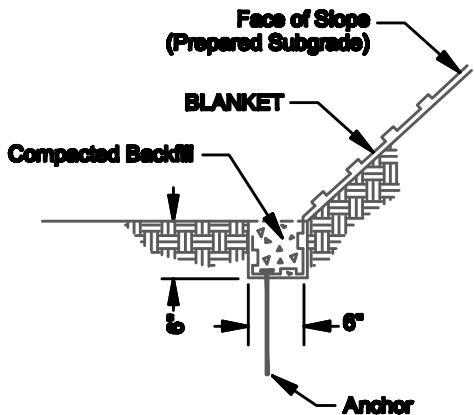

**KEY TRENCH - TOE OF SLOPE**

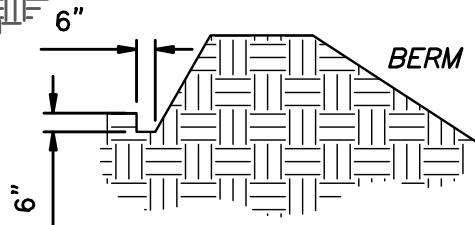

*BERM*

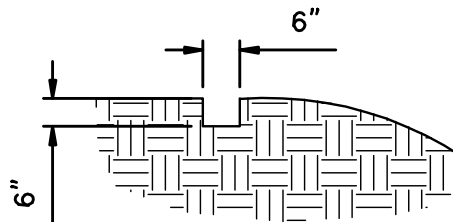

**TOP OF SLOPE ANCHOR SLOT**

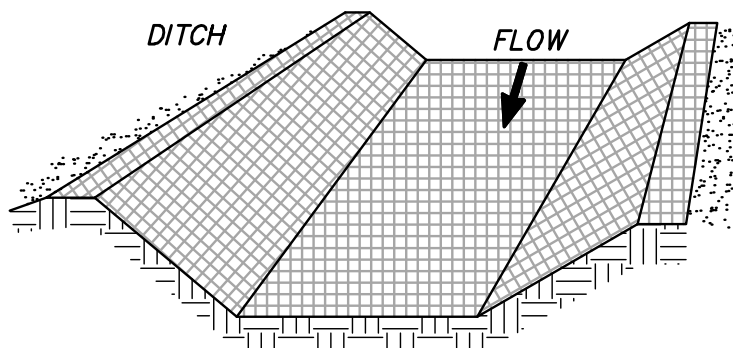

*DITCH*

*FLOW*

**NOTE:**

IN DITCHES, APPLY PROTECTIVE  
COVERING PARALLEL TO THE DIRECTION  
OF FLOW. USE CHECK SLOTS AS REQUIRED.  
AVOID JOINING MATERIAL IN THE CENTER  
OF THE DITCH IF AT ALL POSSIBLE.  
FOLLOW BLANKET MANUFACTURER'S  
RECOMMENDATIONS FOR ALLOWABLE  
VELOCITY AND SHEAR STRESS.

Approved	9/03/2008
Date	
Revisions	



**EROSION CONTROL  
BLANKETS**

**ESC-1a**

**EROSION CONTROL BLANKET NOTES:**

**A) SITE PREPARATION:**

AFTER SITE HAS BEEN SHAPED AND GRADED, PREPARE A FRIABLE SEEDBED RELATIVELY FREE FROM CLODS AND ROCKS MORE THAN 1 1/2 INCHES IN DIAMETER AND ANY FOREIGN MATERIAL THAT WILL PREVENT UNIFORM CONTACT OF THE BLANKET WITH THE SOIL SURFACE.

**B) PLANTING:**

LIME, FERTILIZE, AND SEED IN ACCORDANCE WITH SEEDING OR PLANTING PLAN. WHERE GROUND COVERS ARE TO BE PLANTED, LAY THE PROTECTIVE COVERING FIRST AND THEN PLANT THROUGH THE MATERIAL AS PER PLANTING PLAN.

**C) LAYING AND STAPLING:**

1. START LAYING THE BLANKET FROM THE TOP OF THE CHANNEL OR SLOPE AND UNROLL DOWN-GRADE. ALLOW TO LAY LOOSELY ON SOIL; DO NOT STRETCH.
2. UPSLOPE ENDS OF THE BLANKET SHOULD BE BURIED IN AN ANCHOR SLOT NO LESS THAN 6-INCHES DEEP. TAMP EARTH FIRMLY OVER THE MATERIAL.
3. WHERE MULTIPLE WIDTHS ARE LAID SIDE BY SIDE, THE ADJACENT EDGES SHALL BE OVERLAPPED A MINIMUM OF 6 INCHES AND STAPLED TOGETHER.
4. STAPLES SHALL BE PLACED PER MANUFACTURER'S RECOMMENDATIONS.

**D) TROUBLESHOOTING:**

CONSULT WITH THE ENGINEER, IF ANY OF THE FOLLOWING OCCUR:

1. MOVEMENT OF THE BLANKET OR EROSION UNDER THE BLANKET IS OBSERVED.
2. VARIATIONS IN TOPOGRAPHY ON SITE INDICATE EROSION CONTROL MAT WILL NOT FUNCTION AS INTENDED; CHANGES IN PLAN MAY BE NEEDED, OR A BLANKET WITH A SHORTER OR LONGER LIFE MAY BE NEEDED.
3. DESIGN SPECIFICATIONS FOR SEED VARIETY, SEEDING DATES, OR EROSION CONTROL MATERIALS CANNOT BE MET; SUBSTITUTION MAY BE REQUIRED. UNAPPROVED SUBSTITUTIONS COULD RESULT IN FAILURE TO ESTABLISH VEGETATION.

**E) MAINTENANCE & INSPECTION:**

INSPECT CONTROLS AFTER EACH RAIN EVENT OF 1/2 INCH OR GREATER, AND EVERY 7 DAYS UNTIL VEGETATION IS ESTABLISHED. LOOK FOR EROSION OR UNDERMINING BENEATH THE NETTING, BLANKETS, OR MATS. IF ANY AREA SHOWS EROSION, PULL BACK THAT PORTION OF THE MATERIAL, ADD SOIL, AND RESEED; RESECURE THE MATERIAL IN PLACE. IF NETTING, BLANKETS OR MATS BECOME DISLOCATED OR DAMAGED, REPAIR OR REPLACE AND RESECURE IMMEDIATELY.

**F) JOINING BLANKETS:**

OVERLAP THE END OF THE PREVIOUS ROLL A MINIMUM OF 6 INCHES AND STAPLE. STAPLE ACROSS THE END OF THE ROLL JUST BELOW THE ANCHOR SLOT AND ACROSS THE MATERIAL EVERY 6 INCHES.

**G) TERMINAL END:**

AT THE POINT AT WHICH THE MATERIAL IS DISCONTINUED, OR WHERE THE BLANKET MEETS A STRUCTURE OF SOME TYPE, STAPLE A MINIMUM OF EVERY 12 INCHES.

**H) FINAL CHECK:**

THESE INSTALLATION CRITERIA MUST BE ADHERED TO:

1. ALL DISTURBED AREAS ARE SEEDED.
2. PROTECTIVE BLANKET IS IN UNIFORM CONTACT WITH THE SOIL.
3. ALL LAP JOINTS ARE SECURE.
4. ALL STAPLES ARE DRIVEN FLUSH WITH THE GROUND.

<p>_____ Approved</p>	<p>9/03/2008 Date</p>		<p><b>EROSION CONTROL BLANKETS</b></p>	<p><b>ESC-1a</b></p>
<p>Revisions</p>				
<p> </p>				

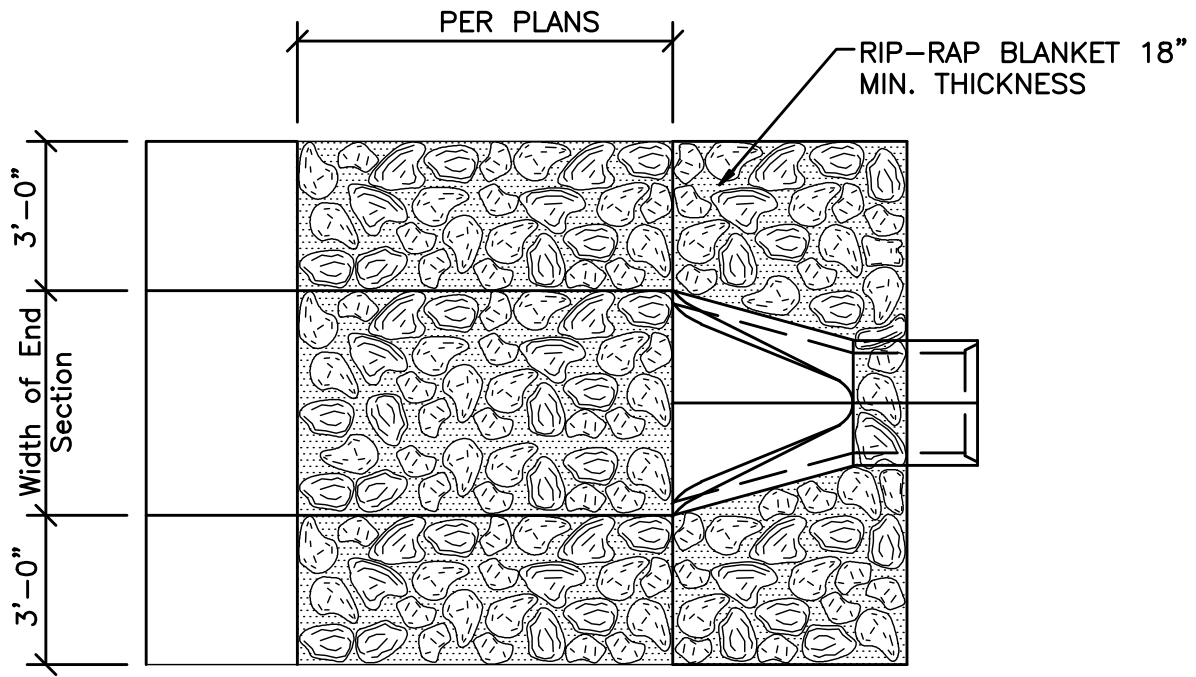

PLAN

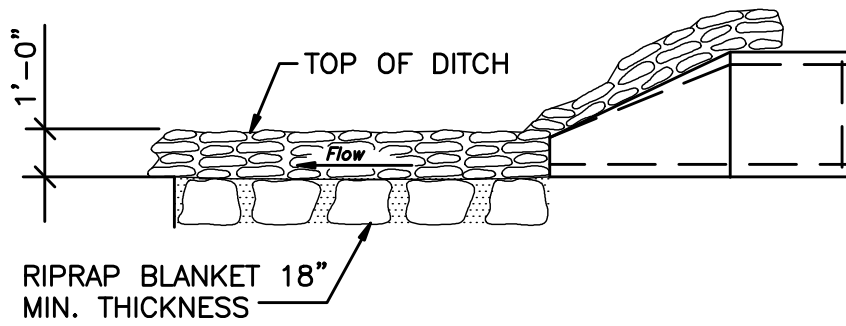

ELEVATION

Approved	9/03/2008
Date	
Revisions	



**OUTLET PROTECTION**

**ESC-2**

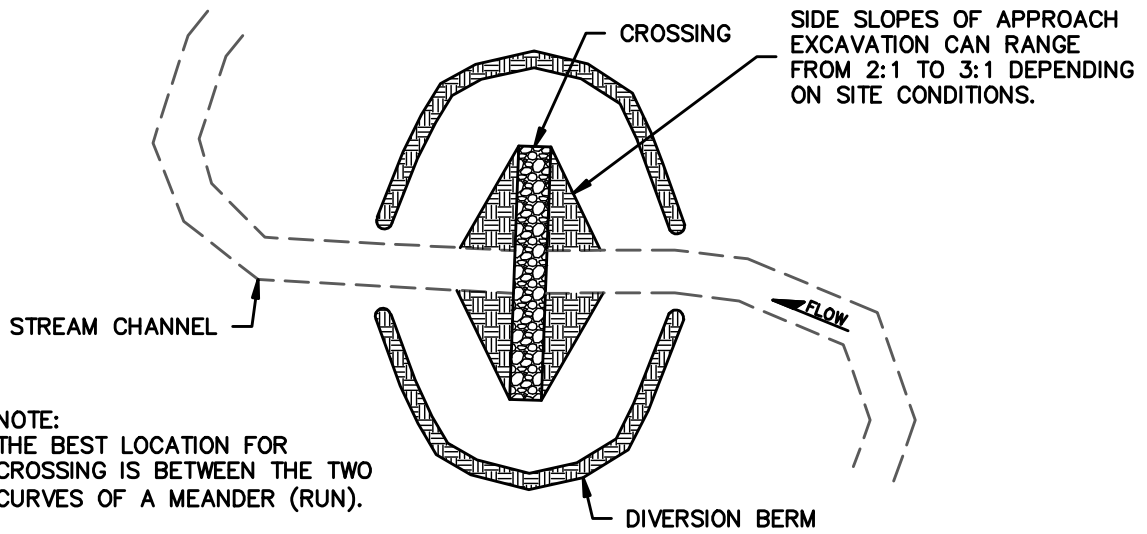

**REINFORCED STREAM CROSSING LAYOUT**  
NOT TO SCALE

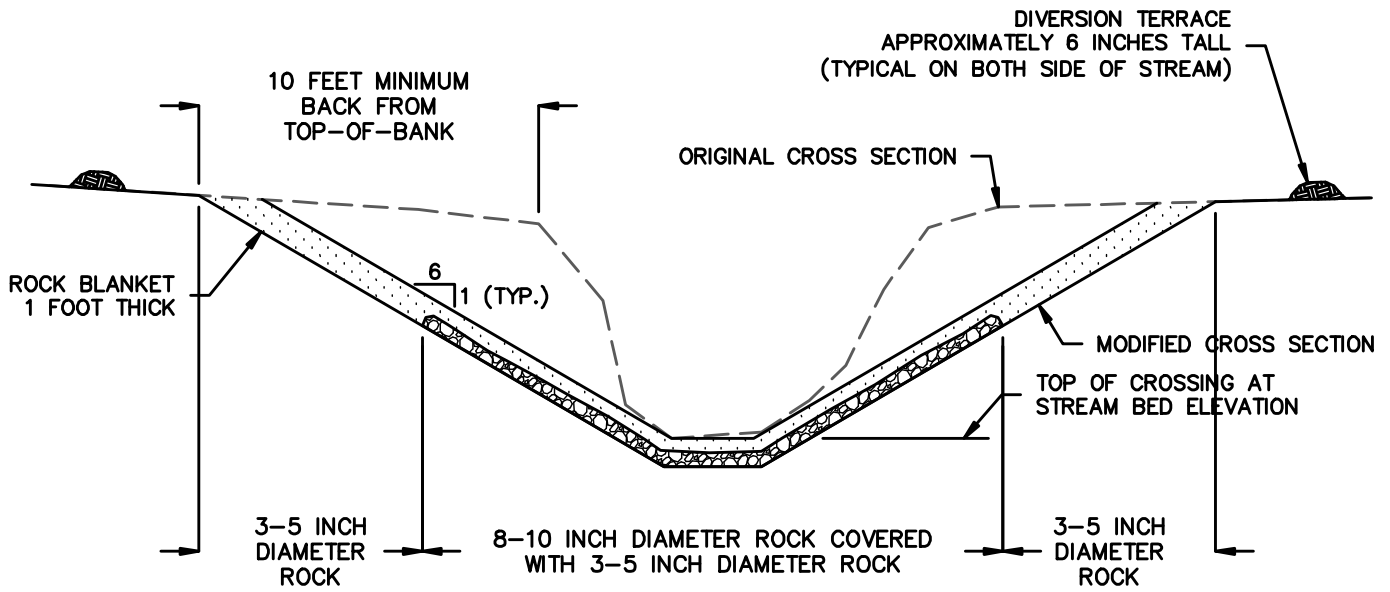

**REINFORCED STREAM CROSSING PROFILE**  
NOT TO SCALE

Approved	9/03/2008
Revisions	Date



**REINFORCED STREAM CROSSING**

**ESC-3**



GENERAL NOTES AND SPECIFICATIONS FOR TEMPORARY (REINFORCED) STREAM CROSSINGS:

1. THE STREAM BED FOR 0.5 MILE BELOW THE PROPOSED CROSSING MUST BE VERTICALLY STABLE. THE CHANNEL SHOULD NOT BE DOWNCUTTING (NO HEADCUTS DOWNSTREAM) OR RAPIDLY FILLING WITH SEDIMENT.
2. LOW FLOW WATER DEPTH SHALL BE LESS THAN SIX INCHES.
3. STREAM BANKS IN THE VICINITY (0.25 MILES UPSTREAM AND DOWNSTREAM) MUST BE STABLE.
4. THE CROSSING SHOULD BE LOCATED IN THE STRAIGHT REACH BETWEEN TWO BENDS.
5. APPROACHES SHOULD BE NO STEEPER THAN 6:1.
6. THE APPROACHES AND CROSSING SHOULD BE OVER EXCAVATED ONE FOOT THAN THE DESIRED SURFACE.
7. THE CROSSING AND THE APPROACHES FOR 10 FEET ON EITHER SIDE OF THE CROSSING SHOULD BE BACKFILLED WITH 8-10 INCH DIAMETER ROCK OR QUARRY RUN SHOT-ROCK TO WITHIN THREE TO FIVE INCHES OF THE DESIRED SURFACE. THE LARGE ROCK SHOULD BE COMPACTED INTO THE STREAM BED AND THE APPROACHES.
8. AFTER THE LARGE ROCK IS COMPACTED, THREE TO FIVE INCH DIAMETER ROCK SHOULD BE PLACED IN THE REMAINDER OF THE APPROACHES AND OVER THE LARGE ROCK TO PROVIDE A RELATIVELY SMOOTH SURFACE.
9. FINAL ELEVATION OF THE PORTION OF THE CROSSING SUBMERGED AT LOW FLOW SHALL NOT BE MORE THAN THREE INCHES ABOVE STREAM BED ELEVATION.
10. SIDE SLOPES OF THE APPROACH CAN RANGE FROM 2:1 TO 3:1 DEPENDING ON CONDITIONS AT THE SITE.
11. SIX INCH TALL DIVERSION BERM SHOULD BE BUILT AROUND THE CROSSING TO PREVENT OVERLAND FLOW FROM ERODING THE APPROACHES. THE DIVERSIONS SHOULD OUTLET AT STABLE LOCATIONS.
12. GROUTING (POURING CONCRETE OVER ROCK) IS PROHIBITED.
13. THE CROSSING SHOULD BE INSPECTED AFTER EACH FLOOD. BE ALERT FOR SIGNIFICANT SCOUR DOWNSTREAM OF THE CROSSING. THE SMALL DIAMETER ROCK MAY HAVE TO BE REPLACED OVER TIME. FREQUENT CLEARING OF SEDIMENT AND DEBRIS FROM THE APPROACHES WILL BE NECESSARY.

Approved _____ Date 9/03/2008		<b>REINFORCED <u>STREAM</u> CROSSING</b>	<b>ESC-3</b>
Revisions _____			

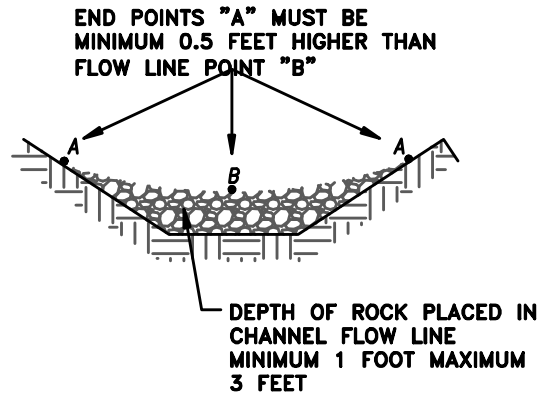
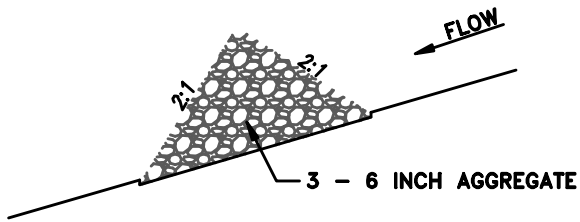

**FRONT VIEW**

PLACE DOWNSTREAM STRUCTURE SUCH THAT POINT "B" IS APPROXIMATELY LEVEL WITH THE TOE ELEVATION OF THE UPSTREAM STRUCTURE

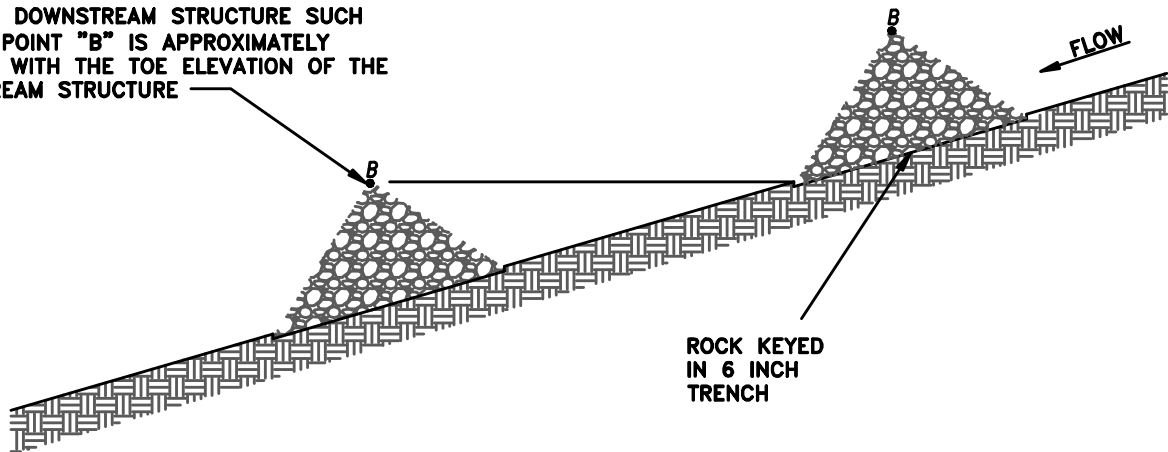

**SIDE VIEW**

**NOTE:**

ROCK CHECK DAMS SHALL BE USED ONLY FOR DRAINAGE AREAS LESS THAT 10 ACRES UNLESS APPROVED BY THE ENGINEER.

Approved	9/03/2008
Date	
Revisions	



**CHECK DAM**

**ESC-4**

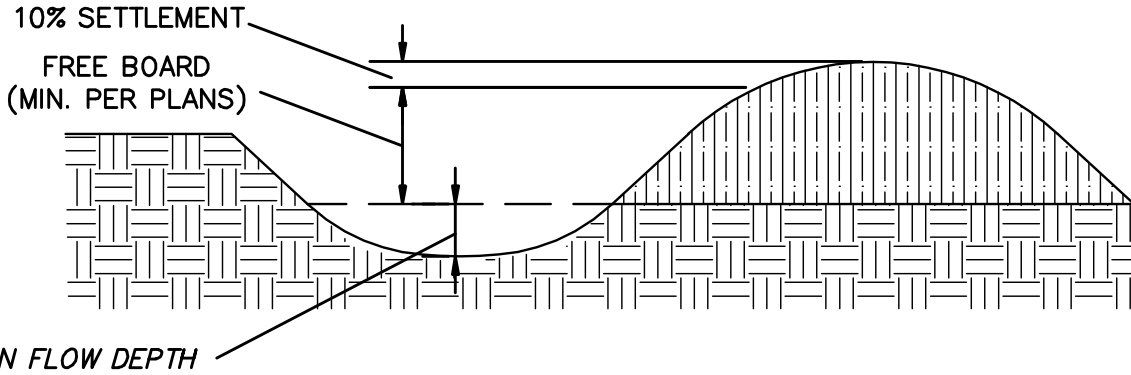

**NOTES:**

1. TEMPORARY DIVERSION BERMS MUST BE INSTALLED AS A FIRST STEP IN THE LAND-DISTURBING ACTIVITY AND MUST BE FUNCTIONAL PRIOR TO LAND DISTURBANCE.
2. THE OUTLET OF THE DIVERSION SHALL BE LOCATED IN AN UNDISTURBED OR STABILIZED AREA.
3. TEMPORARY OR PERMANENT SEEDING AND MULCH SHALL BE APPLIED TO THE BERM IMMEDIATELY FOLLOWING ITS CONSTRUCTION.
4. ALL TREES, BRUSH, STUMPS, OBSTRUCTIONS, AND OTHER OBJECTIONABLE MATERIAL SHALL BE REMOVED AND DISPOSED OF SO AS NOT TO INTERFERE WITH THE PROPER FUNCTIONING OF THE DIVERSION.
5. THE DIVERSION SHALL BE EXCAVATED OR SHAPED TO LINE, GRADE, AND CROSS-SECTION AS REQUIRED AND FREE OF IRREGULARITIES WHICH WILL IMPEDE FLOW.
6. FILLS SHALL BE COMPACTED AS NEEDED TO PREVENT UNEQUAL SETTLEMENT THAT WOULD CAUSE DAMAGE IN THE COMPLETED DIVERSION. FILL SHALL BE COMPOSED OF SOIL WHICH IS FREE FROM EXCESSIVE ORGANIC DEBRIS, ROCKS, OR OTHER OBJECTIONABLE MATERIALS.
7. ALL EARTH REMOVED AND NOT NEEDED IN CONSTRUCTION SHALL BE SPREAD OR DISPOSED OF SO THAT IT WILL NOT INTERFERE WITH THE FUNCTIONING OF THE DIVERSION.
8. THE BERM SHOULD BE ADEQUATELY COMPACTED TO PREVENT FAILURE.
9. THE BERM SHOULD BE LOCATED TO MINIMIZE DAMAGES BY CONSTRUCTION OPERATIONS AND TRAFFIC.

_____ Approved	9/03/2008 Date		<h2 style="margin: 0;">DIVERSION BERM/SWALE</h2>	<h2 style="margin: 0;">ESC-5</h2>
Revisions				
_____ _____				

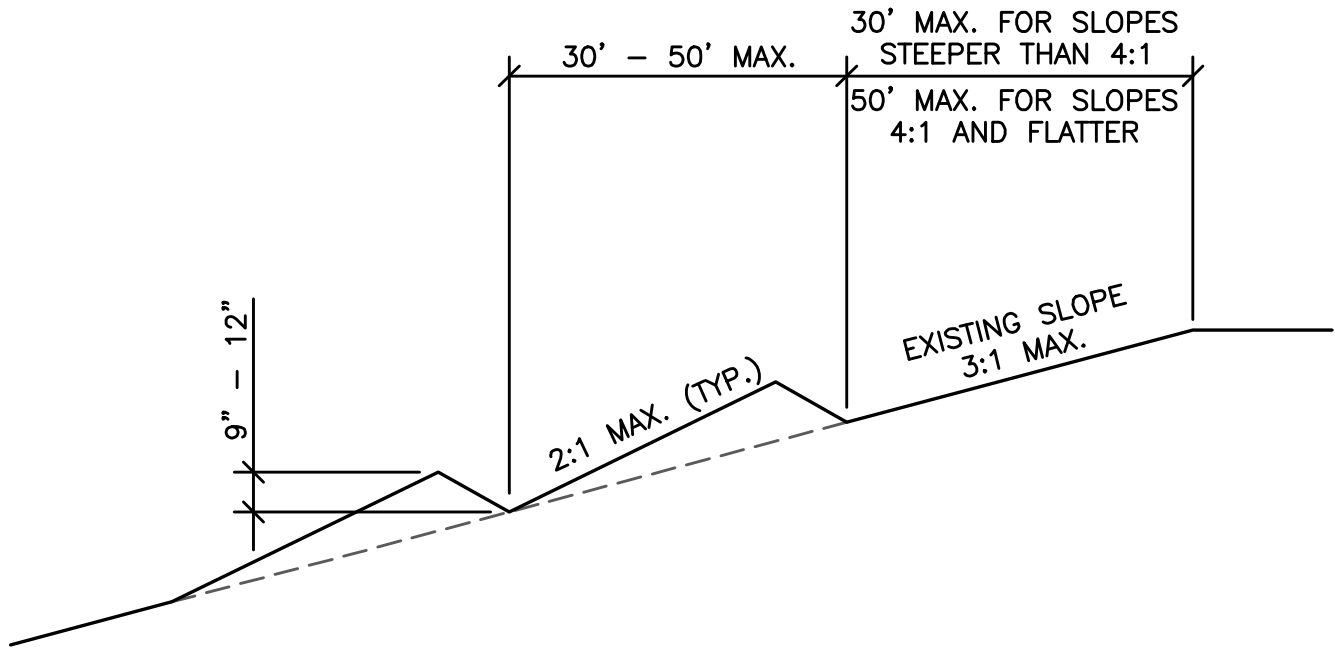

NOTES:

1. MAXIMUM CONTINUOUS LENGTH OF 2:1 SLOPE SHALL BE 15'.
2. TERRACE SHALL HAVE A TRANSVERSE SLOPE AT 1% TO 3% AND DRAIN TO AN ADEQUATELY PROTECTED OUTLET.
3. TERRACES MAY ONLY BE FORMED BY CONSTRUCTION OF A BERM.

Approved	9/03/2008
	Date
Revisions	



# TERRACING

**ESC-6**

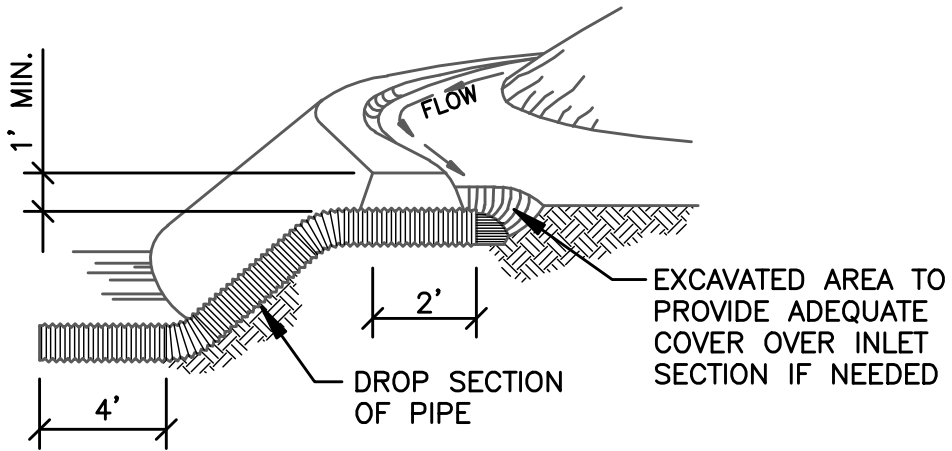

PERSPECTIVE

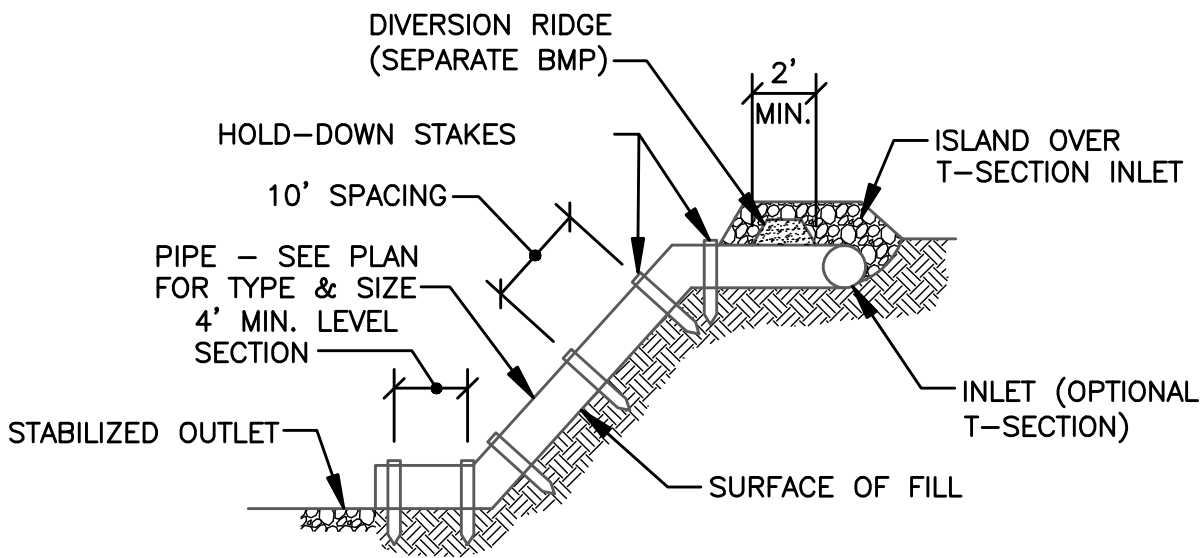

PROFILE

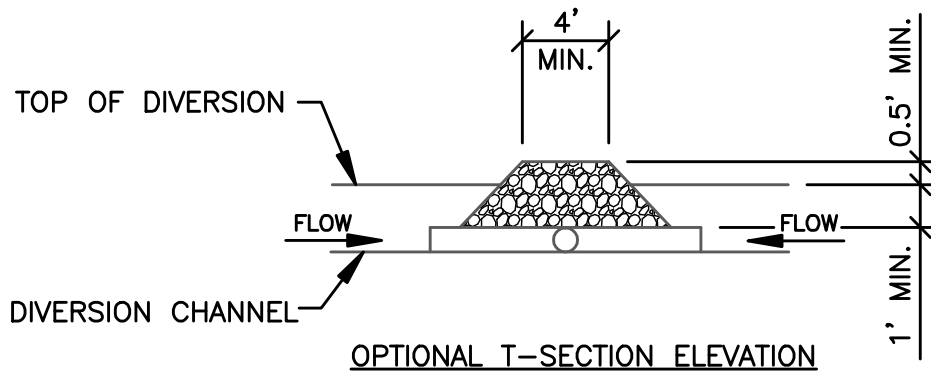

Approved	9/03/2008
Revisions	Date



**SLOPE DRAINS**

**ESC-7**

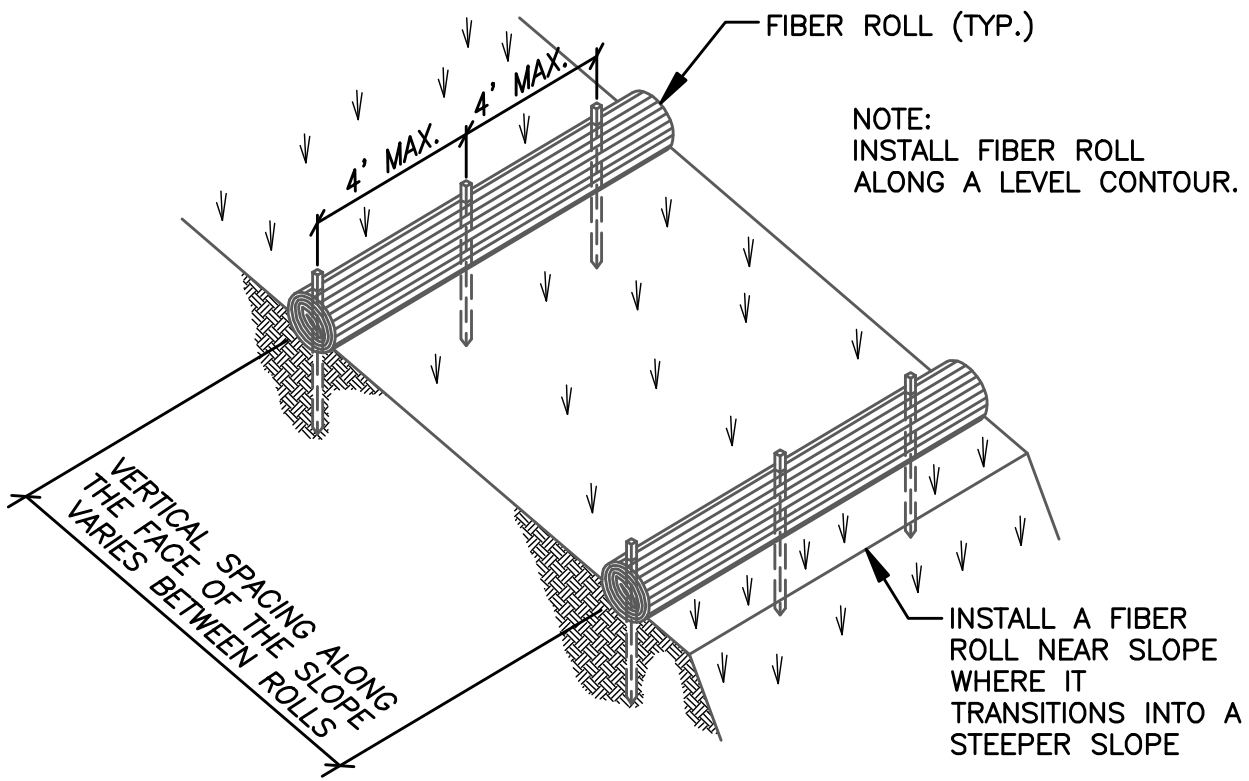

TYPICAL FIBER ROLL INSTALLATION

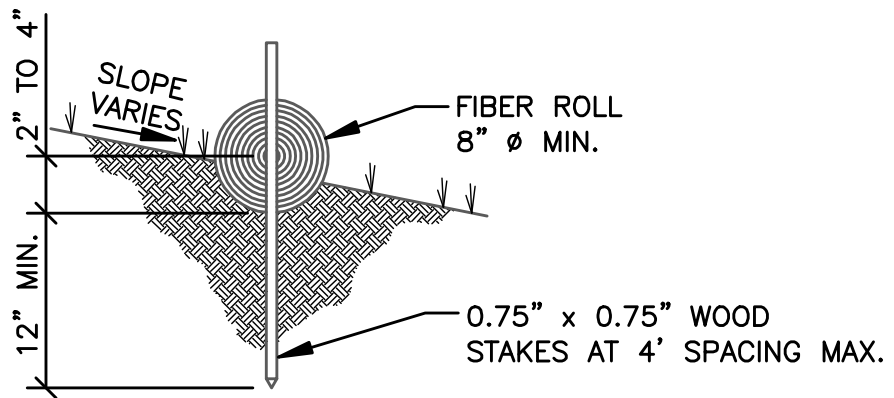

ENTRENCHMENT DETAIL

Approved	9/03/2008
Revisions	Date



**FIBER ROLLS/WATTLES**

**ESC-8**

1. EXCAVATE A 6"x4" TRENCH

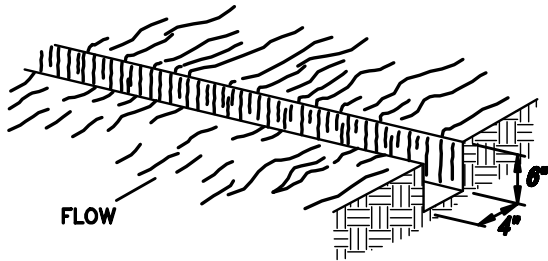

2. SET THE STAKES ALONG THE DOWN SLOPE SIDE OF THE TRENCH.

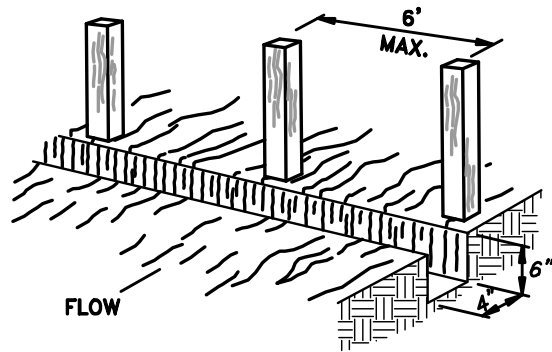

3. STAPLE GEOTEXTILE MATERIAL TO STAKES AND EXTEND IT INTO AND AROUND THE BOTTOM OF THE TRENCH.

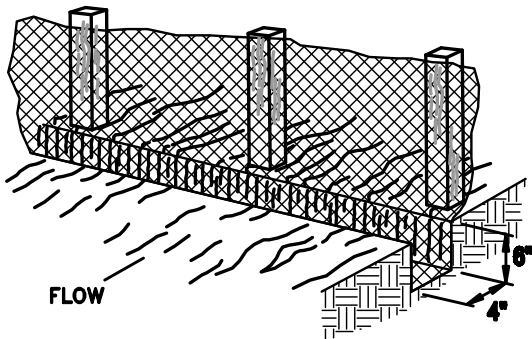

4. BACK FILL AND COMPACT THE EXCAVATED SOIL OVER THE GEOTEXTILE IN THE TRENCH.

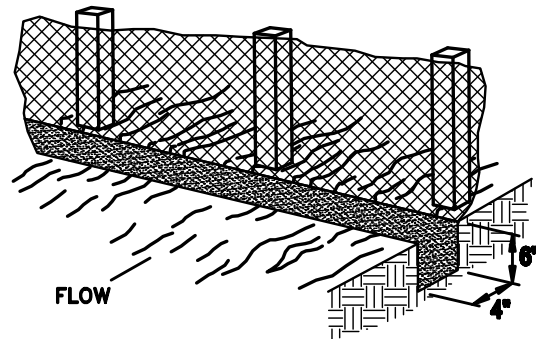

**SHEET FLOW INSTALLATION  
(PERSPECTIVE VIEW)  
NOT TO SCALE**

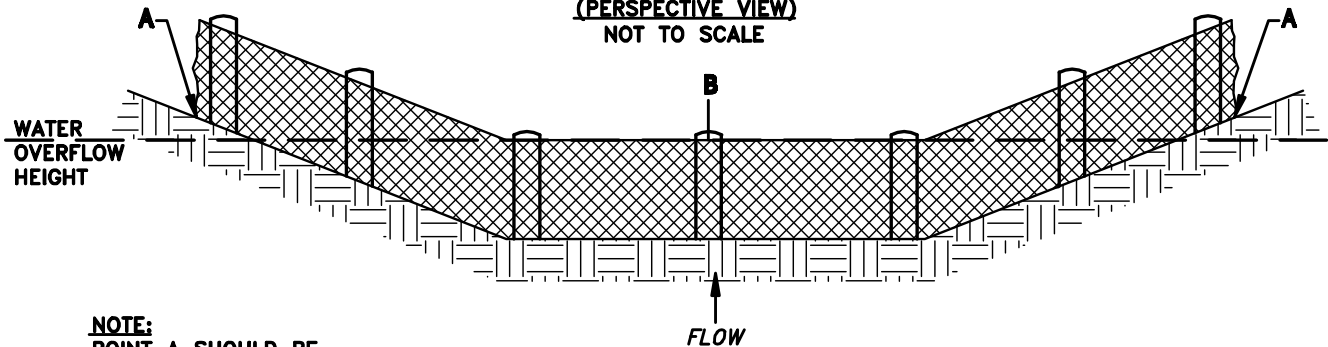

**NOTE:**  
POINT A SHOULD BE  
HIGHER THAN POINT B.

**DRAINAGE WAY INSTALLATION  
(FRONT ELEVATION)  
NOT TO SCALE**

Approved	9/03/2008 Date
Revisions	



**SILT FENCE**

**ESC-9a**

**SILT FENCE NOTES:**

**A) INSTALLATION**

1. THE HEIGHT OF SILT FENCE SHALL BE A MINIMUM OF 16 INCHES ABOVE THE ORIGINAL GROUND SURFACE AND SHALL NOT EXCEED 34 INCHES ABOVE THE GROUND SURFACE.
2. THE FABRIC SHALL BE PURCHASED IN A CONTINUOUS ROLL CUT TO LENGTH OF THE BARRIER TO AVOID THE USE OF JOINTS. WHEN JOINTS ARE UNAVOIDABLE, FILTER CLOTH SHALL BE SECURELY SPLICED TOGETHER ONLY AT SUPPORT POSTS, WITH A MAX 6 INCH OVERLAP.
3. DIG A TRENCH AT LEAST 6 INCHES DEEP AND 4 INCHES WIDE ALONG THE TRENCH ALIGNMENT.
4. DRIVE POSTS AT LEAST 24 INCHES INTO THE GROUND ON THE DOWNSLOPE SIDE OF THE TRENCH. SPACE POSTS A MAXIMUM OF 6 FEET APART.
5. THE SEDIMENT FABRIC SHALL BE FASTENED SECURELY TO THE UPSLOPE SIDE OF THE POSTS USING A MINIMUM OF ONE INCH LONG, HEAVY-DUTY WIRE STAPLES OR TIE-WIRES, AND EIGHT INCHES OF THE FABRIC SHALL BE EXTENDED INTO THE TRENCH. THE FABRIC SHALL NOT BE STAPLED TO EXISTING TREES.
6. PLACE THE BOTTOM 1 FOOT OF FABRIC IN THE MINIMUM-OF-6-INCH DEEP TRENCH, LAPPING TOWARD THE UPSLOPE SIDE. BACK FILL WITH COMPACTED EARTH OR GRAVEL.
7. IF A SILT FENCE IS TO BE CONSTRUCTED ACROSS A DITCH LINE OR SWALE, IT MUST BE OF SUFFICIENT LENGTH TO ELIMINATE ENDFLOW, AND THE PLAN CONFIGURATION SHALL RESEMBLE AN ARC OR HORSESHOE, PLACED ON A CONTOUR, WITH THE ENDS ORIENTED UPSLOPE. EXTRA-STRENGTH SEDIMENT FABRIC SHALL BE USED WITH A MAXIMUM 3-FOOT SPACING OF POSTS.
8. TO REDUCE MAINTENANCE, EXCAVATE A SHALLOW SEDIMENT STORAGE AREA IN THE UPSLOPE SIDE OF THE FENCE. PROVIDE GOOD ACCESS IN AREA OF HEAVY SEDIMENTATION FOR CLEAN OUT AND MAINTENANCE.
9. SILT FENCES SHALL BE REMOVED WHEN THEY HAVE SERVED THEIR USEFUL PURPOSE, BUT NOT BEFORE THE UPSLOPE AREA HAS BEEN PERMANENTLY STABILIZED.
10. INSTALLATION WITH SLICING METHOD IS PREFERRED.

**B) TROUBLESHOOTING:**

1. DETERMINE THE EXACT LOCATION OF UNDERGROUND UTILITIES, BEFORE FENCE INSTALLATION SO UTILITIES ARE NOT DISTURBED.
2. GRADE ALIGNMENT OF FENCE NEEDED TO PROVIDE A BROAD, NEARLY LEVEL AREA UPSTREAM OF FENCE TO ALLOW SEDIMENT COLLECTION AREA.

**C) INSPECTION MAINTENANCE:**

1. INSPECT SILT FENCES AT LEAST ONCE A WEEK AND AFTER EACH 1/2" OF RAINFALL. MAKE ANY REQUIRED REPAIRS IMMEDIATELY.
2. SHOULD THE FABRIC OF A SEDIMENT FENCE COLLAPSE, TEAR, DECOMPOSE, OR BECOME INEFFECTIVE, REPLACE IT PROMPTLY.
3. REMOVE SEDIMENT DEPOSITS AS NECESSARY TO PROVIDE ADEQUATE STORAGE VOLUME FOR THE NEXT RAIN AND TO REDUCE PRESSURE ON THE FENCE. AVOID DAMAGING OR UNDERMINING THE FENCE DURING CLEANOUT. SEDIMENT ACCUMULATION SHOULD NOT EXCEED 1/2 THE HEIGHT OF THE FENCE.
4. REMOVE ALL FENCING MATERIALS AND UNSTABLE SEDIMENT DEPOSITS, AND BRING THE AREA TO GRADE AND STABILIZE IT AFTER THE CONTRIBUTING DRAINAGE AREA HAS BEEN PROPERLY AND COMPLETELY STABILIZED.

_____ Approved	9/03/2008 Date
Revisions	



**SILT FENCE NOTES**

**ESC-9b**



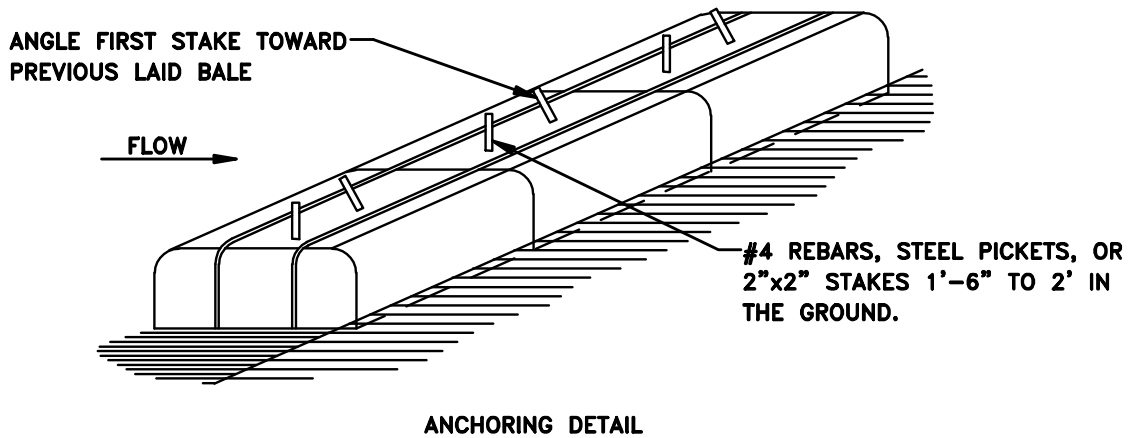
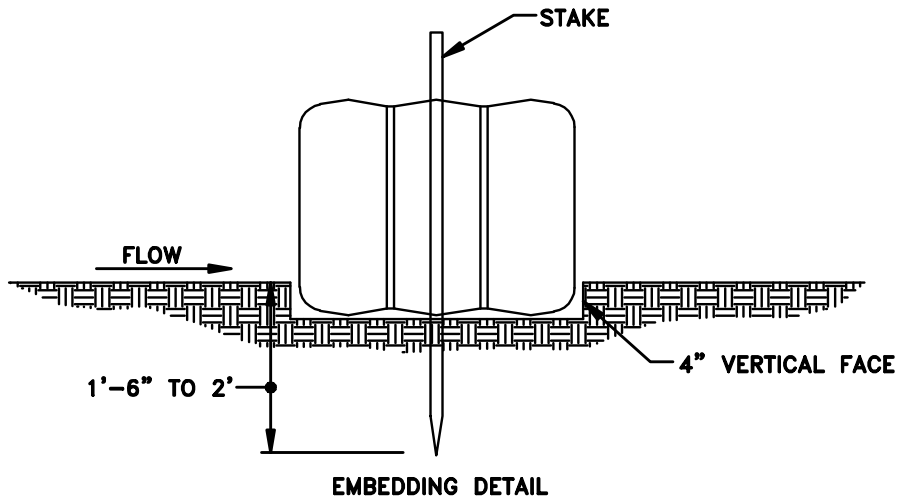

1. BALES SHALL BE PLACED IN A ROW WITH ENDS TIGHTLY ABUTTING THE ADJACENT BALES.
2. EACH BALE SHALL BE EMBEDDED IN THE SOIL A MINIMUM OF 4".
3. BALES SHALL BE SECURELY ANCHORED IN PLACE BY STAKES OR RE-BARS DRIVEN THROUGH THE BALES. THE FIRST STAKE IN EACH BALE SHALL BE ANGLED TOWARD PREVIOUSLY LAID BALE TO FORCE BALES TOGETHER.
4. INSPECTION SHALL BE AT LEAST ONCE A WEEK AND AFTER EACH 1/2" RAIN. REPAIR OR REPLACEMENT SHALL BE MADE PROMPTLY.
5. BALES SHALL BE REMOVED BY THE OWNER WHEN THEY HAVE SERVED THEIR USEFULNESS SO AS NOT TO BLOCK OR IMPEDE STORM FLOW OR DRAINAGE.

Approved	9/03/2008 Date
Revisions	



## STRAW BALE DIKE

**ESC-10**

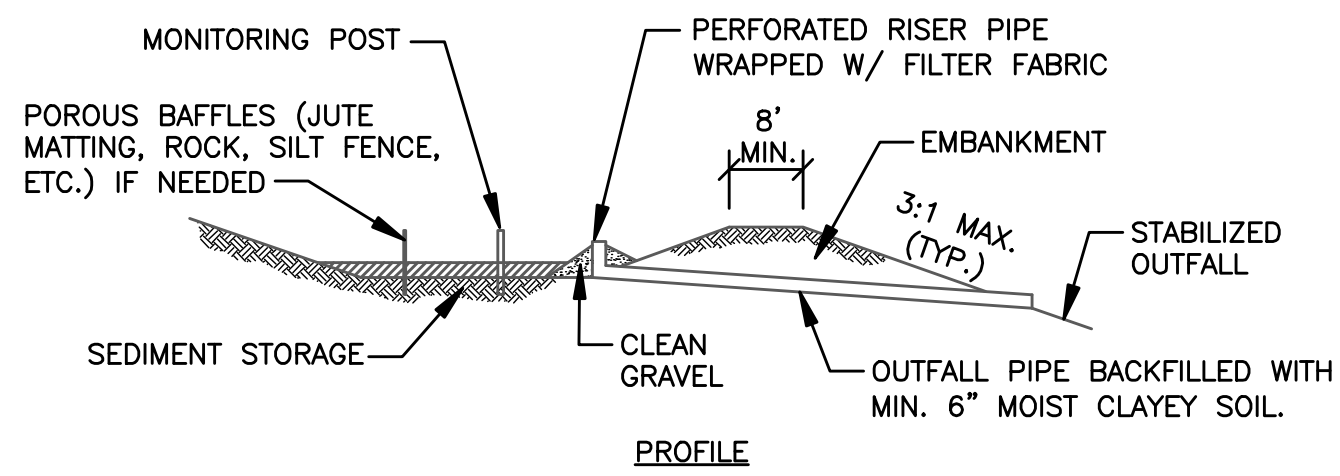
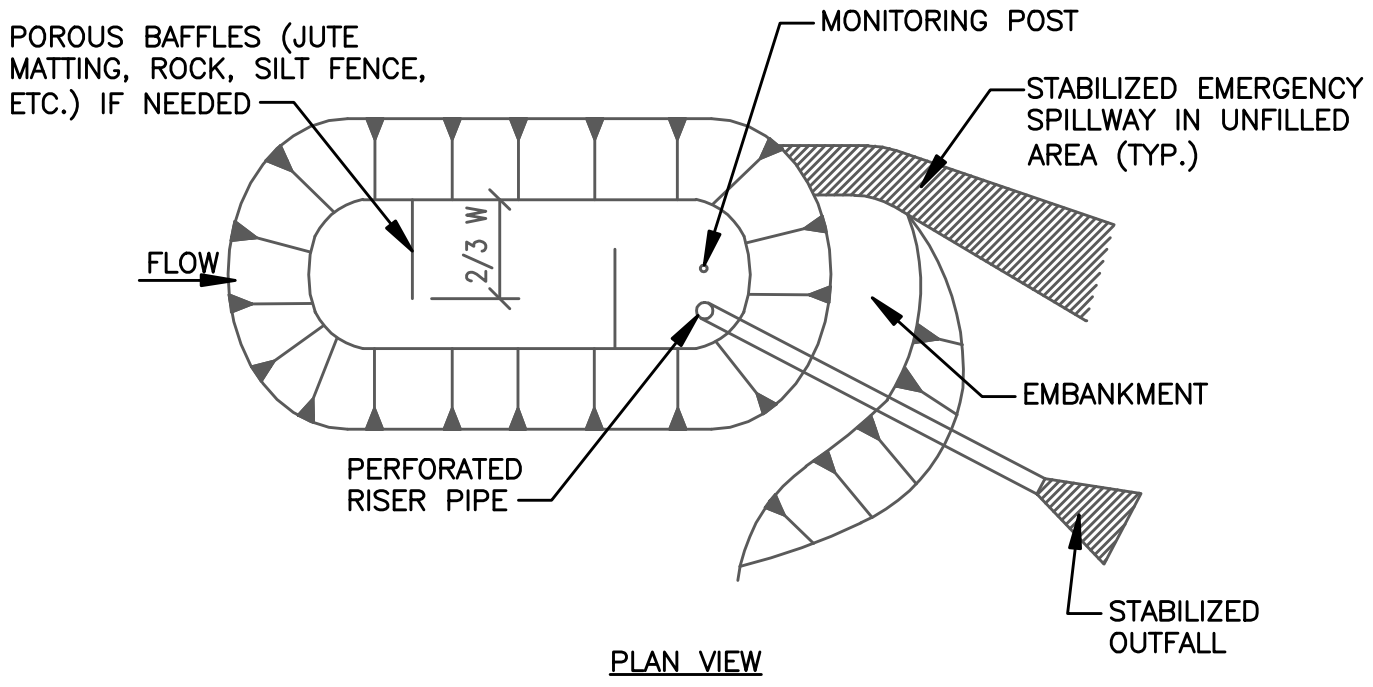

**GENERAL NOTES:**

1. TOP OF RISER SHOULD BE A MIN. OF 1' BELOW THE TOP OF THE EMBANKMENT AND 6" BELOW THE FLOW LINE OF ANY EMERGENCY SPILLWAY.
2. IF NO EMERGENCY SPILLWAY IS PROPOSED THERE SHALL BE A MINIMUM OF 1.5' OF FREEBOARD.
3. BAFFLE HEIGHT SHOULD BE GREATER THAN TOP OF RISER PIPE AND LESS THAN TOP OF EMBANKMENT.
4. SILT MONITORING POSTS SHALL BE INSTALLED NEAR THE OUTLET OF BASIN AND BE MARKED WITH MAXIMUM PERMISSABLE LEVEL OF SEDIMENT.

Approved	9/03/2008
Revisions	Date



**SEDIMENT BASIN**

**ESC-11**

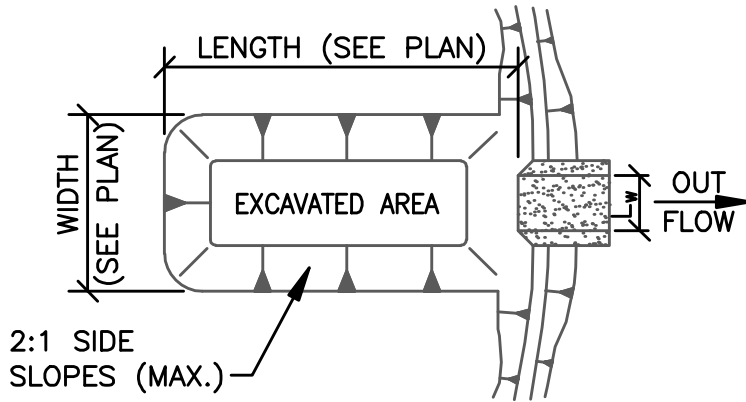

TRIBUTARY AREA (ACRES)	LENGTH OF SPILLWAY WEIR $L_w$ (ft)
0-1.0	4
1.01-2.0	6
2.01-3.0	8
3.01-4.0	10
4.01-5.0	12

PLAN VIEW

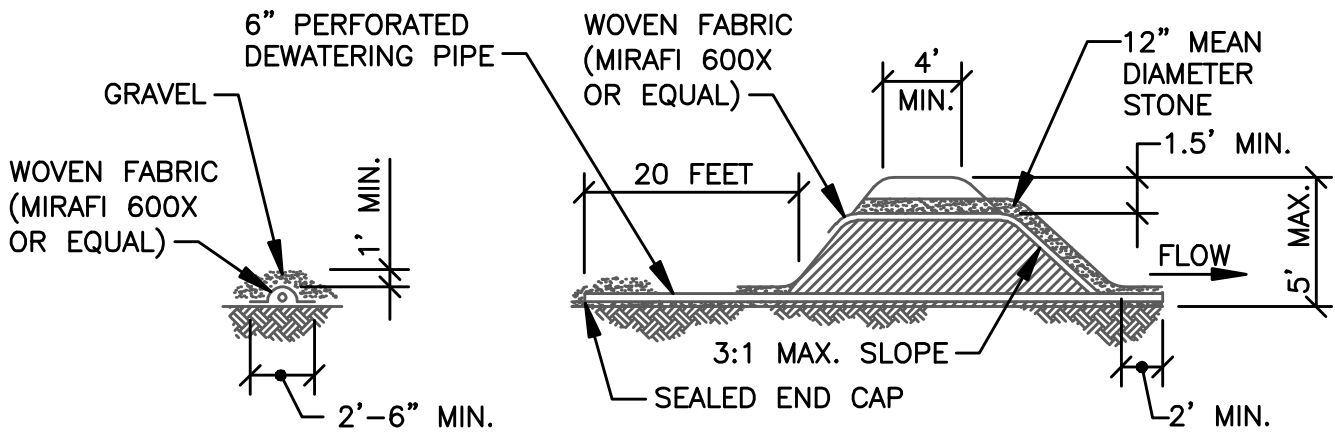

DEWATERING PIPE

OUTLET PROFILE

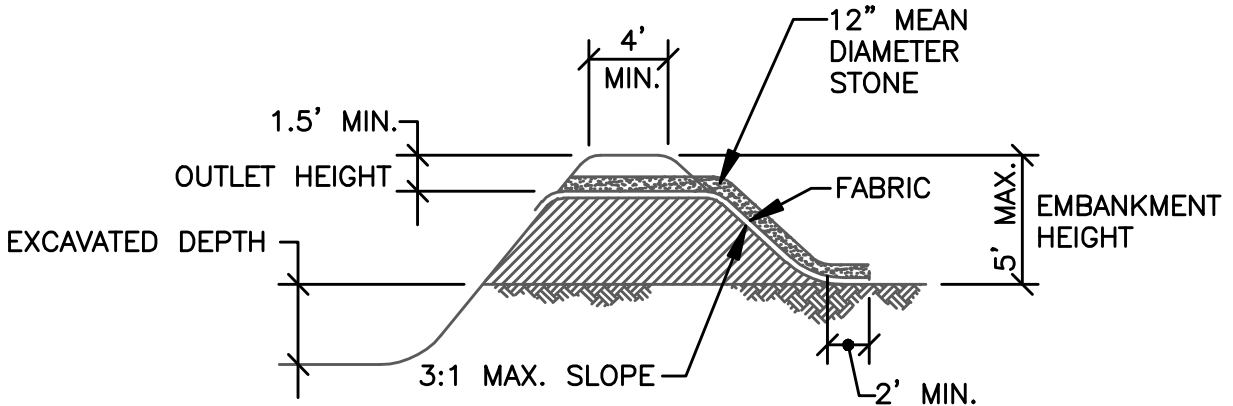

ALTERNATE OUTLET PROFILE

Approved	9/03/2008
Revisions	Date



**SEDIMENT TRAP**

**ESC-12a**

TEMPORARY SEDIMENT TRAP NOTES:

A) CONSTRUCTION SPECIFICATIONS:

1. THE AREA UNDER THE EMBANKMENT SHALL BE CLEARED, GRUBBED, AND STRIPPED OF ANY VEGETATION AND ROOT MAT.
2. FILL MATERIAL FOR THE EMBANKMENT SHALL BE FREE OF ROOTS OR OTHER WOODY VEGETATION, ORGANIC MATERIAL, LARGE STONES, AND OTHER OBJECTIONABLE MATERIAL. THE EMBANKMENT SHOULD BE COMPACTED IN 6-INCH LAYERS BY TRAVERSING WITH CONSTRUCTION EQUIPMENT.
3. THE EARTHEN EMBANKMENT SHALL BE SEEDED WITH TEMPORARY OR PERMANENT VEGETATION IMMEDIATELY AFTER INSTALLATION
4. CONSTRUCTION OPERATION SHALL BE CARRIED OUT TO MINIMIZE EROSION AND WATER POLLUTION.
5. ALL CUT AND FILL SLOPES SHALL BE 2H:1V OR FLATTER EXCEPT FOR EXCAVATED, WET STORAGE AREAS WHICH MAY BE AT A MAXIMUM 1H:1V GRADE.

B) INSPECTION AND MAINTENANCE

1. INSPECT THE TEMPORARY SEDIMENT TRAP WEEKLY AND AFTER EACH STORM EVENT OF 1/2-INCH OR GREATER.
2. REMOVE AND PROPERLY DISPOSE OF SEDIMENT WHEN IT ACCUMULATES TO ONE-HALF THE DESIGN VOLUME.
3. PERIODICALLY CHECK THE EMBANKMENT, SPILLWAY, AND OUTLET APRON FOR EROSION DAMAGE, SETTLING SEEPAGE, OR SLUMPING ALONG THE TOE AND REPAIR IMMEDIATELY.
4. REPLACE THE SPILLWAY GRAVEL FACING IF IT BECOMES CLOGGED.
5. INSPECT VEGETATION AND RESEED IF NECESSARY.
6. REPLACE ANY DISPLACED RIPRAP SO THAT NO REPLACEMENT ROCK IS ABOVE THE DESIGN GRADE.
7. REMOVE THE TEMPORARY SEDIMENT TRAP AFTER THE DRAINAGE AREA HAS BEEN PERMANENTLY STABILIZED, INSPECTED, AND APPROVED. DO SO BY DRAINING ANY WATER, REMOVING THE SEDIMENT TO A DESIGNATED DISPOSAL AREA, AND GRADING THE SITE TO BLEND WITH THE SURROUNDING AREA; THEN STABILIZE.

_____ Approved	9/03/2008 Date		<b>SEDIMENT TRAP</b>	<b>ESC-12b</b>
_____ Revisions				
_____				

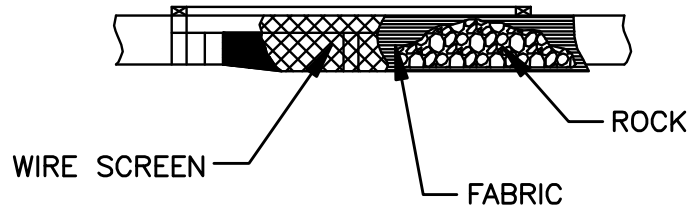
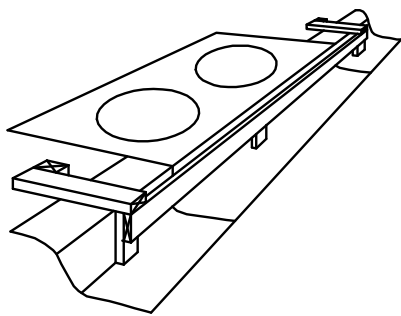
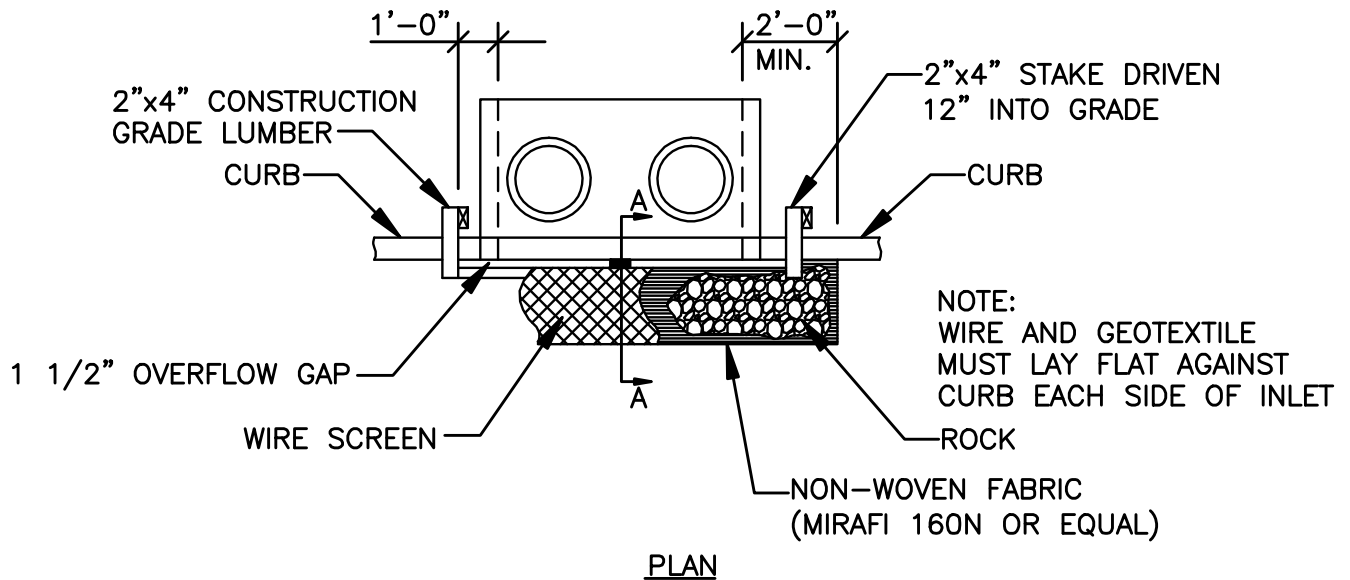

WOODEN FRAME ON VERTICAL CURB

NOTE: ALTERNATIVELY, ROCK CAN BE PLACED IN A FILTER FABRIC BAG (SIMILAR TO SANDBAG) AND PLACED IN THE OPENING WITHOUT THE WOODEN FRAME.

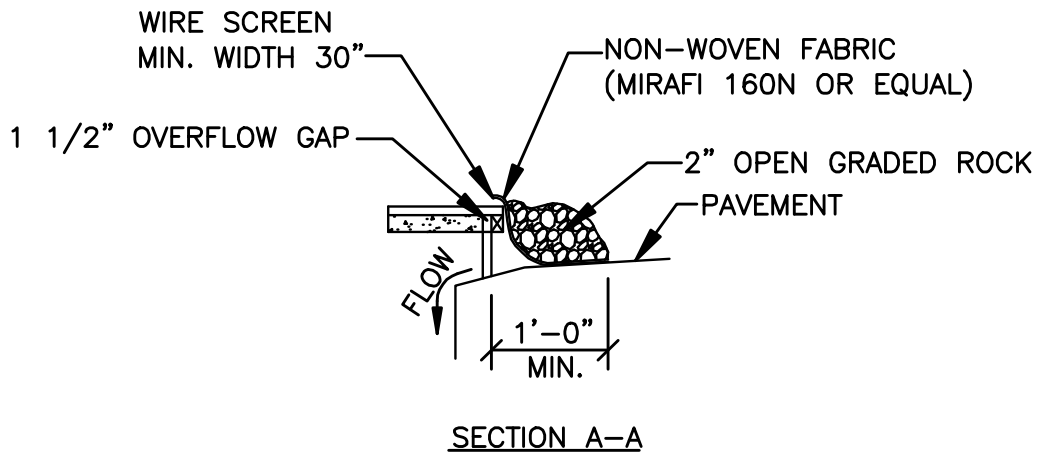

Approved	9/03/2008
Date	
Revisions	



**CURB INLET PROTECTION**

**ESC-13**

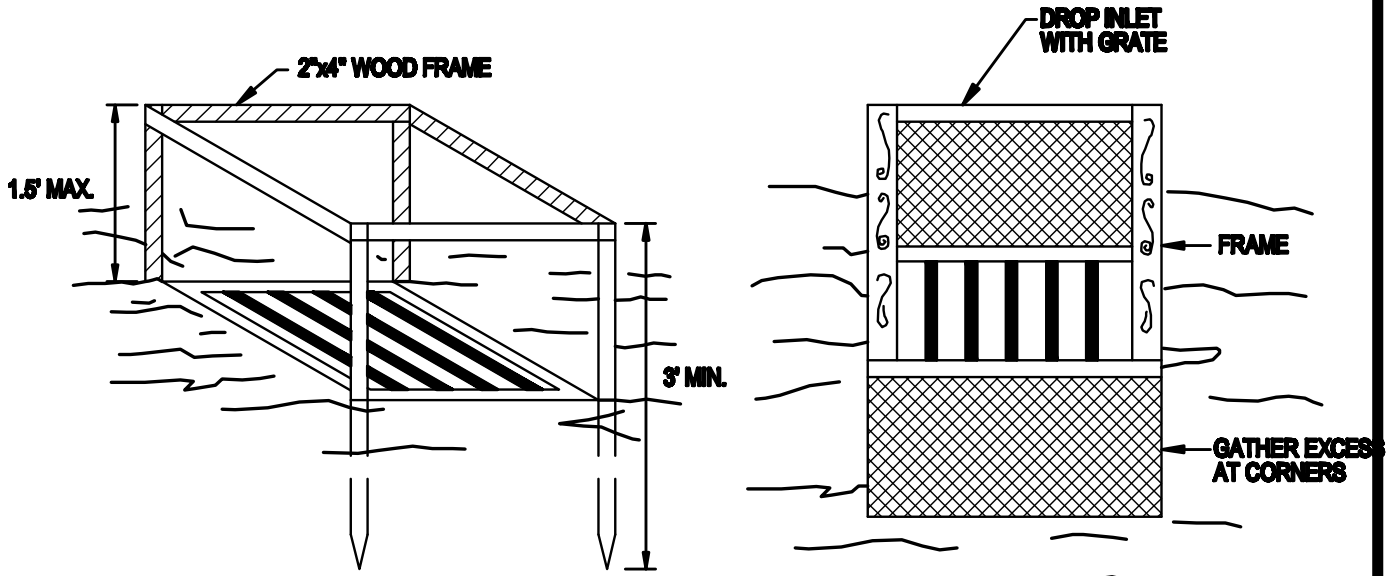

**PERSPECTIVE VIEWS  
NOT TO SCALE**

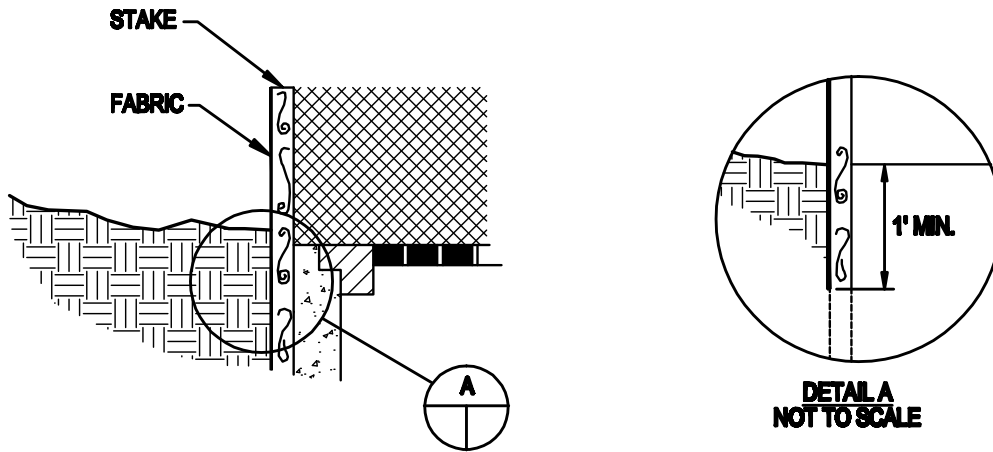

**ELEVATION OF STAKE AND  
FABRIC ORIENTATION**

**DETAIL A  
NOT TO SCALE**

Approved	9/03/2008
Date	
Revisions	



**DROP INLET PROTECTION  
(SILT FENCE)**

**ESC-14a**

**SEDIMENT FENCE DROP INLET PROTECTION NOTES:**

**A) CONSTRUCTION SPECIFICATIONS:**

1. SEDIMENT FENCE SHALL BE CUT FROM A CONTINUOUS ROLL TO AVOID JOINTS.
2. FOR STAKES, USE 2X4 WOOD OR EQUIVALENT METAL WITH A MINIMUM LENGTH OF 3 FEET.
3. SPACE STAKES EVENLY AROUND THE PERIMETER OF THE INLET A MAXIMUM OF 3 FEET APART, AND SECURELY DRIVE THEM INTO THE GROUND, APPROXIMATELY 18 INCHES DEEP.
4. TO PROVIDE NEEDED STABILITY TO THE INSTALLATION, FRAME WITH 2X4 WOOD STRIPS AROUND THE CREST OF THE OVERFLOW AREA AT A MAXIMUM OF 1.5 FEET ABOVE THE DROP INLET CREST.
5. PLACE THE BOTTOM 12 INCHES OF THE FABRIC IN A TRENCH AND BACK FILL THE TRENCH WITH 12-INCHES OF COMPACTED SOIL.
6. FASTEN FABRIC SECURELY BY STAPLES, OR WIRE IT TO THE STAKES AND FRAME. JOINTS MUST BE OVERLAPPED TO THE NEXT STAKE.

**B) INSPECTION AND MAINTENANCE:**

1. THE STRUCTURE SHALL BE INSPECTED WEEKLY AND AFTER EACH RAIN EVENT OF 1/2 INCH OR GREATER AND REPAIRS MADE AS NEEDED.
2. SEDIMENT SHALL BE REMOVED AND THE TRAP RESTORED TO ITS ORIGINAL DIMENSIONS WHEN THE SEDIMENT HAS ACCUMULATED TO ONE HALF THE DESIGN DEPTH OF THE TRAP. REMOVED SEDIMENT SHALL BE DEPOSITED IN A SUITABLE AREA AND IN SUCH A MANNER THAT IT WILL NOT ERODE.
3. STRUCTURES SHALL BE REMOVED AND THE AREA STABILIZED WHEN THE REMAINING DRAINAGE AREA HAS BEEN PROPERLY STABILIZED.

_____	9/03/2008
Approved	Date
_____	
Revisions	
_____	
_____	



**DROP INLET PROTECTION  
(SILT FENCE)  
NOTES**

**ESC-14b**

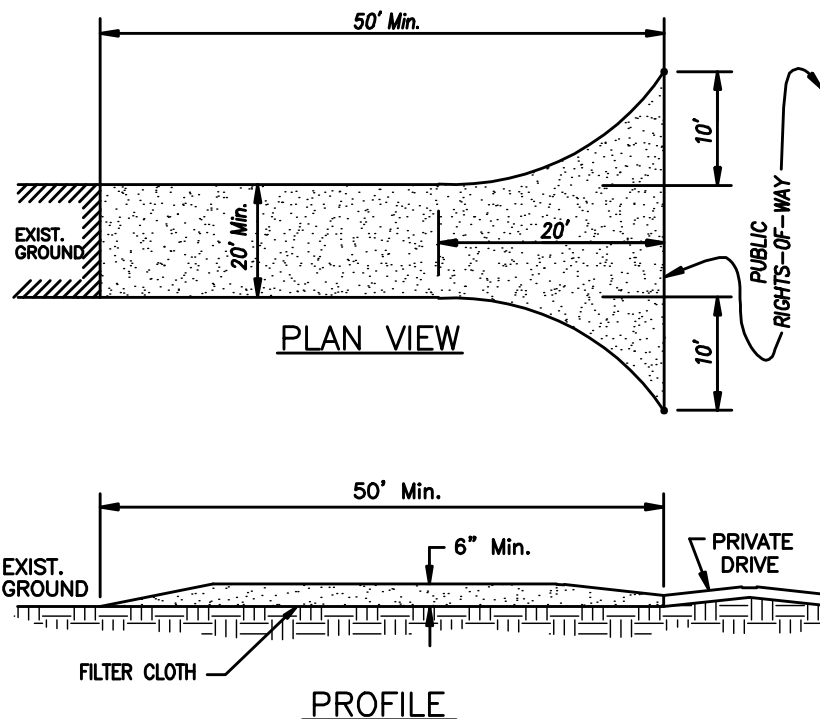

**CONSTRUCTION SPECIFICATIONS**

1. STONE SIZE – USE 2" STONE.
2. LENGTH – AS REQUIRED, BUT NOT LESS THAN 50 FEET.
3. THICKNESS – NOT LESS THAN SIX (6) INCHES.
4. WIDTH – TWENTY (20) FOOT MINIMUM, BUT NOT LESS THAN THE FULL WIDTH AT POINTS WHERE INGRESS OR EGRESS OCCURS.
5. FILTER CLOTH – WILL BE PLACED OVER THE ENTIRE AREA PRIOR TO PLACING OF STONE.
6. SURFACE WATER – ALL SURFACE WATER FLOWING OR DIVERTED TOWARD CONSTRUCTION ENTRANCES SHALL BE PIPED ACROSS THE ENTRANCE. IF PIPING IS IMPRACTICAL, A MOUNTABLE BERM WITH 3:1 SLOPES WILL BE PERMITTED.
7. MAINTENANCE – THE ENTRANCE SHALL BE MAINTAINED IN A CONDITION WHICH WILL PREVENT TRACKING OR FLOWING OF SEDIMENT ONTO PUBLIC RIGHTS-OF-WAY. THIS MAY REQUIRE PERIODIC TOP DRESSING WITH ADDITIONAL STONE AS CONDITIONS DEMAND AND REPAIR AND/OR CLEANOUT OF ANY MEASURES USED TO TRAP SEDIMENT. ALL SEDIMENT SPILLED, DROPPED, WASHED OR TRACKED ONTO PUBLIC RIGHTS-OF-WAY MUST BE REMOVED IMMEDIATELY.
8. PERIODIC INSPECTION AS NEEDED MAINTENANCE SHALL BE PROVIDED WEEKLY AND AFTER EACH RAIN EVENT GREATER THAN 1/2".

Approved	9/03/2008
Date	
Revisions	



**CONSTRUCTION  
ENTRANCE/EXIT**

**ESC-15**